



# **SLS™ CSB115 and CSB115-CM User's Guide**

Issue 1

26 August 2020

---

---

# Dolby Laboratories, Inc.

## Corporate Headquarters

**Dolby Laboratories, Inc.**  
1275 Market Street  
San Francisco, CA 94103-1410 USA  
**Telephone** 415-558-0200  
**Fax** 415-645-4000  
[www.dolby.com](http://www.dolby.com)

## European Headquarters

**Dolby International AB**  
Apollo Building, 3E  
Herikerbergweg 1-35  
1101 CN Amsterdam Zuidoost  
The Netherlands  
**Telephone** 31-20-651-1800  
**Fax** 31-20-651-1801

## Technical Support

Dolby Laboratories  
Portal: <http://customer.dolby.com>  
Email: [cinemasupport@dolby.com](mailto:cinemasupport@dolby.com)

Region	Support Phone Numbers
Americas	+1-415-645-4900
EMEA	+44-33-0808-7700
APAC	+86-400-692-6780
Japan	+81-3-4540-6782

### **LIMITED WARRANTY AND WARRANTY EXCLUSIONS:**

THE LIMITED WARRANTY AND WARRANTY EXCLUSIONS MAY BE FOUND AT THE FOLLOWING URL:  
<https://www.dolby.com/us/en/about/warranty-and-maintenance-policies.html>.



## IMPORTANT SAFETY INSTRUCTIONS



1. **INSTALLER ASSUMES ALL RESPONSIBILITY AND LIABILITY FOR THE INSTALLATION OF THIS PRODUCT.**
2. Prior to installing this product, read and completely understand the installation instructions. You must read these instructions to prevent personal injury and property damage. Keep the installation instructions in an easily accessible location for future reference.
3. Installation must be performed by qualified, licensed, and insured installers, and installed in accordance with all laws, rules, and regulations applicable to the installation site. Failure to do so could result in serious personal injury or even death. Consult an installation professional if you do not understand the installation instructions.
4. Compliance with local building codes (and, where applicable, national codes) is the responsibility of the installer. Installers should consult with local regulatory authorities for specific codes and/or guidelines for the use of this product.
5. Use proper personal lifting techniques when working with heavy objects to avoid personal injury.
6. Any supplied rigging hardware is intended only for use with the specified loudspeaker. The installer assumes all risk of loss and/or injury arising out of the use of the supplied rigging hardware with any other loudspeaker.
7. This guide is meant only for the purpose of instructing the installer in the intended use of SLS supplied rigging. All other rigging is considered part of the venue and/or installer supplied equipment and is not addressed in this guide.
8. This guide is not a comprehensive source for rigging in general. Installer assumes all responsibility for ensuring that accepted rigging and safety practices are employed. Installer assumes all responsibility for the appropriate use of SLS supplied rigging hardware and follows at a minimum all applicable laws, rules, and regulations in force for each venue.
9. Do not install on a structure that is prone to abnormal vibration, movement, or chance of impact. Failure to do so could result in damage to the equipment and/or damage to the mounting surface.
10. Make sure that no water pipes, natural gas lines, electrical wire, or conduit are present where the speaker is to be installed. Cutting or drilling into water pipes, natural gas lines, electrical wire, or conduit could cause serious personal injury or property damage.
11. Prior to installation, always inspect all hardware components for wear, deformations, corrosion, and missing or damaged parts.
12. No open flame sources should be placed on or near the apparatus. Do not install near any heat sources such as radiators, heat registers, stoves, or other apparatus that produces heat.
13. Only clean product with a dry or damp cloth.
14. Do not block any ventilation openings.
15. Hearing damage may result from prolonged exposure to excessive sound pressure levels (SPL). The loudspeaker is easily capable of generating SPL sufficient to cause permanent hearing damage to performers, production crew, and audience members. Caution should be taken to avoid prolonged exposure to SPL in excess of 90 dB.

16. The products covered by this manual are not intended for use in high moisture environments. Moisture can damage the product and cause corrosion of electrical contacts and metal parts. Use in dry indoor locations only. Premature product failure or serious personal injury could occur if this product is used outdoors or in wet indoor environments. Do not expose these products to rain.
17. Keep speakers out of extended or intense direct sunlight.
18. The loudspeaker can generate considerable acoustical energy and may move during use. The system must be mounted in a way that allows sufficient clearance for this movement without risk of contact with the building structure, rigging, or other equipment.
19. Installed systems should be inspected at least annually or as required by local laws. The inspection shall include a visual survey of all corners and load bearing surfaces for signs of cracking, water damage, delamination, or any other condition that may decrease the strength of the rigging frame and speakers. The rigging hardware must be inspected for fatigue at least annually or as required by local laws. The inspection shall include a visual survey of the hardware for signs of corrosion, bending, or any other condition that may decrease the strength of the hardware.
20. THIS APPARATUS IS NOT INTENDED FOR STAND-ALONE FLOOR-STANDING INSTALLATIONS WITH NO ANCHORAGE.
21. DO NOT SUSPEND, HANG, OR FLY THIS APPARATUS.  
THIS APPARATUS MUST BE INSTALLED ACCORDING TO THE INSTRUCTIONS IN THIS MANUAL.
22. No information contained in this guide is intended as a warranty on the part of SLS. Anyone using this information assumes all liability arising from its use. Product abuse, use of the product not in accordance with SLS instructions, or use in an application for which the product has not been designed is not covered under any SLS warranty, nor is SLS liable for any loss or damage.

---

# Table of Contents

<b>Chapter 1 Introduction .....</b>	<b>1</b>
1.1 CSB115 and CSB115-CM Overview .....	1
1.2 CSB115 and CSB115-CM Specifications .....	1
1.3 Processor Settings .....	2
<b>Chapter 2 Installing the Speakers .....</b>	<b>3</b>
2.1 Installing with the CS50 or CS50-CM Mid/High Loudspeaker .....	3
2.2 Connecting Audio .....	6
2.3 Testing the Speaker for Buzzing or Rattling .....	7
2.4 Dimensions .....	7
<b>Appendix A Environmental Compliance and Regulations.....</b>	<b>9</b>
A.1 EU Environmental Regulations and Compliance.....	9
A.2 Russian Environmental Regulations and Compliance.....	9
<b>Appendix B Setting System Limiters.....</b>	<b>11</b>
B.1 Setting up System Limiters .....	11

---

---

# Introduction

## 1.1 CSB115 and CSB115-CM Overview

The SLS™ CSB115 and CSB115-CM are cinema loudspeakers that are designed for use as the low frequency component in screen channel systems for 5.1 and 7.1 cinema auditoriums and small Dolby Atmos® equipped auditoriums. You can couple these units with the CS50-CM or CS100MH-CM mid/high screen-channel loudspeakers.

The CSB115 and CSB115-CM provide dedicated inserts and bolts for use with the mounting yokes that are included with the CS50-CM and CS100MH-CM.



Figure 1-1 CSB115 and CSB115-CM Front View

## 1.2 CSB115 and CSB115-CM Specifications

Following are the CSB115 and CSB115-CM general specifications\*:

- Frequency response: 45 Hz to 800 Hz
- Sensitivity: 1 watt @ 1 M: 95 dB
- Continuous power rating: 450 watts
- Maximum continuous rated SPL at 1 meter: 122dB
- Driver: 15-inch low frequency
- Size
  - Width: 23 inches (584 millimeters)
  - Height: 22.2 inches (564 millimeters)
  - Depth: 15.25 inches (387 millimeters)
- Net weight: 49 pounds (22.2 kilograms)
- Shipping weight: 61.7 pounds (28 kilograms)

\* SLS Audio reserves the right to make changes to existing products without notice.

## 1.3 Processor Settings

Following are the CSB115 and CSB115-CM processor settings. (SLS Audio reserves the right to make changes to existing products without notice.)

Crossover Section	Frequency	Slope	Delay <sup>1</sup>	Gain <sup>2</sup>	Phase
Highpass filter	40 Hz	24 dB Octave (fourth order) Butterworth	0 ms		In
Lowpass filter	80 Hz	24 dB Octave (fourth order) Linkwitz-Riley	0 ms	0 dB	

- 1 Some digital signal processors change the propagation delay for each output depending on how much processing is on that channel.
- 2 Assumes amplifiers have equal voltage gain.

### 1.3.1 System 100A Bi Amp

Following are the System 100A Bi amp specifications for a CSB115 or CSB115-CM when paired with a CS50 or CS50-CM.

Crossover Section	Frequency	Slope	Delay	Gain <sup>1</sup>	Phase
Highpass filter	80 Hz	24 dB Octave (fourth order) Linkwitz/Riley		-6 dB	In

- 1 Assumes amplifiers have equal voltage gain.

Equalization Section <sup>1</sup>	Frequency	Q	Bandwidth <sup>2</sup>	Level
Low frequency	None required			0
High frequency/medium frequency	None			

- 1 Equalization settings were developed in an anechoic environment.
- 2 Different DSP manufactures are not consistent in their implementation of digital parametric equalizations. SLS recommended filters are not replicated by all DSP devices. If the DSP device being used continuously varies the bandwidth of the filter depending on the gain, the DSP does not match our settings. (Most of these devices do not allow filter Q to be shown.)

Limiting Section <sup>1</sup>	Threshold/RMS Voltage	Attack	Release
Low frequency	40 V	16 ms	256 ms
High frequency/medium frequency	31 V	8 ms	128 ms

- 1 See [Appendix B](#)



# Installing the Speakers

## 2.1 Installing with the CS50 or CS50-CM Mid/High Loudspeaker

This chapter provides instructions for installing the SLS™ CSB115 and CSB115-CM.



**Warning:** TO PREVENT INJURY, THIS APPARATUS MUST BE SECURELY ATTACHED TO THE FLOOR/WALL BUILDING STRUCTURE IN ACCORDANCE WITH THE INSTALLATION INSTRUCTIONS. CONSULT A PROFESSIONAL MECHANICAL OR STRUCTURAL ENGINEER TO OBTAIN APPROVAL FOR ALL ATTACHMENTS TO THE BUILDING STRUCTURE. THIS APPARATUS MUST BE INSTALLED BY LICENSED PROFESSIONAL INSTALLERS. IF NOT ATTACHED TO THE BUILDING STRUCTURE PROPERLY, THIS APPARATUS COULD FALL AND CAUSE PERSONAL INJURY OR DEATH. THE CSB115 AND CSB115-CM ARE NOT DESIGNED TO BE FLYABLE. ALL HARDWARE ATTACHMENT POINTS ON THE CSB115 AND CSB115-CM ARE FOR MID/HIGH YOKE ATTACHMENT ONLY AND NOT FOR SUSPENSION OR SAFETY EYEBOLTS. INSPECT ALL COMPONENTS BEFORE INSTALLATION. THIS APPARATUS IS NOT INTENDED FOR FLOOR-STANDING INSTALLATIONS WITH NO ANCHORAGE. ALL LOCAL BUILDING AND SEISMIC CODES MUST BE ADHERED TO.

### 2.1.1 Tools Required for CSB115 Installation

- 7/32-inch Allen wrench to remove the bolts for installation of the mid/high yokes into the available 3/8"-16 installation points
- 5/32-inch Allen wrench to anchor the mid-high cabinet vertical angle
- Tools and installer-supplied hardware to anchor the CSB115 to the building structure
- #2 Phillips screwdriver for attaching speaker wire to the barrier strip

### 2.1.2 Tools Required for CSB115-CM Installation

- 6 mm Allen wrench to remove the bolts for installation of the mid/high yokes into the available installation points
- Tools and installer-supplied hardware to anchor the CSB115-CM to the building structure
- 5/32-inch Allen wrench to anchor the mid-high cabinet vertical angle
- #2 Phillips screwdriver for attaching the speaker wire to the barrier strip

### 2.1.3 CSB115 and CSB115-CM Orientation

When used with the CS50 or CS50-CM, you must position the CSB115 or CSB115-CM with the yoke-mounting bolts on the top of the speaker, as shown in the following figure.

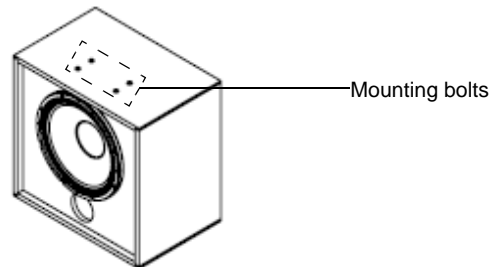

**Figure 2-1** Correct Speaker Orientation

To prevent screen channel movement during operation, you must secure the speaker to a platform that is attached to the building structure with installer-supplied hardware. The following figure shows an example of installer-supplied hardware that you can use for this purpose.

We recommend #10 × 2" wood screws or 4-5 mm diameter wood screws to penetrate the speaker cabinet by a minimum of 0.75-inch (19 mm) to a maximum of 1.5-inches (38 mm). To attach an angled steel plate to the speaker, the wood screws must be at least 2 inches (51 mm) apart.

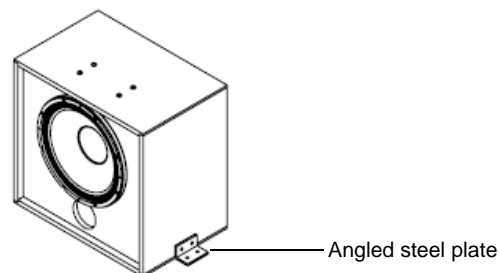

**Figure 2-2** Use Installer-Supplied Hardware to Anchor CSB115/CSB115-CM



---

**Warning:** THE CSB115 OR CSB115-CM MAY VIBRATE OUT OF POSITION IF NOT SECURED TO A PLATFORM ATTACHED TO THE BUILDING STRUCTURE. CONSULT A PROFESSIONAL MECHANICAL OR STRUCTURAL ENGINEER TO APPROVE ALL ATTACHMENTS TO THE BUILDING STRUCTURE. USE AN APPROPRIATE SIZE AND QUANTITY OF FASTENERS TO SECURE HARDWARE TO THE BUILDING STRUCTURE. WE RECOMMEND #10 × 2" WOOD SCREWS OR 4-5 mm DIAMETER SCREWS. HARDWARE MUST BE SECURELY TIGHTENED.

---

## 2.1.4 Installing the Yoke

A yoke is provided with the CS50 and CS50-CM for mounting on top of the CSB115/CSB115-CM. To install the yoke:

1. Remove the four bolts on the top of the speaker using the 7/32-inch Allen wrench for the CSB115 or the 6 mm Allen wrench for the CSB115-CM, as shown in the following figure.
2. Position the yoke with the two slots on the sides of the yoke arms positioned toward the back of the speaker.

These slots enable you to tilt the mid/high speaker forward and secure it at the correct angle. If the mid/high speaker needs to rotate up, turn the yoke 180 degrees from what is shown in the figure.

3. Align the yoke over the top of the four holes, reinsert the bolts through the yoke, and tighten.

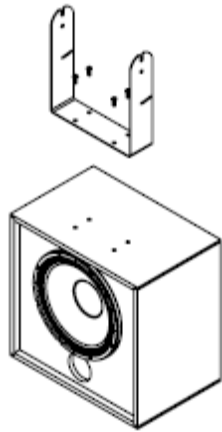

**Figure 2-3** Installing the Yoke on the CSB115/CSB115-CM

### 2.1.5 Attaching the CS50 or CS50-CM to the CSB115/CSB115-CM

To attach the CS50 or CS50-CM:

1. Loosen the two bolts on the side of the mid/high cabinet using a 7/32" Allen wrench (for the CSB115) or 6 mm Allen wrench (for CSB115-CM), as shown in the following figure.  
Be sure that there is enough space for the yoke to slide between the screw and cabinet side.
2. Remove the two vertical set bolts from the CS50 or CS50-CM using the 5/32-inch Allen wrench.
3. Place the cabinet into the top slots in the yoke and loosely tighten the bolts.
4. Set the vertical angle of the cabinet, and then tighten the two bolts.
5. Insert the vertical set bolts and tighten to anchor in the vertical angle.

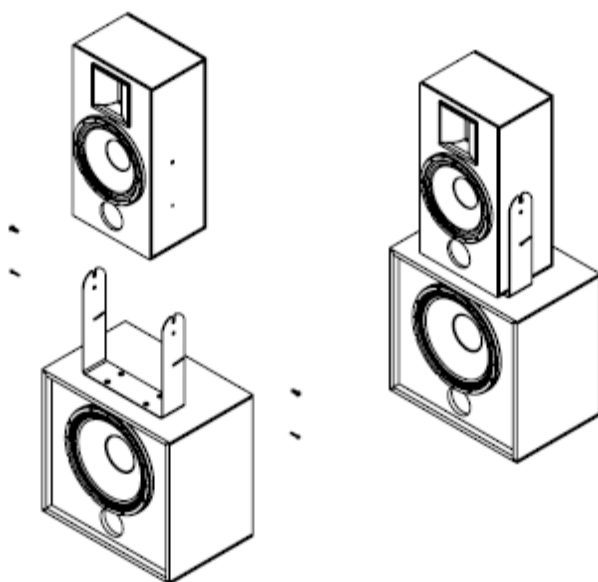

Figure 2-4 Attaching the CS50-CM or CS50-CM to the CSB115/CSB115-CM

## 2.2 Connecting Audio

The input barrier strip accepts 16- to 12- gauge wire, with either #6 spade lugs or bare wire. Always use industry-standard practices for selecting wire gauge, based on the product power rating and cable length. Note that the barrier strip is marked with a plus (+) or red indicator to show the polarity. Always tie down the cable to available hardware to minimize any buzzing or pullouts.



---

**Warning:** TURN OFF ALL AMPLIFIERS WHEN CONNECTING THE LOUDSPEAKER WIRING.

---

## 2.3 Testing the Speaker for Buzzing or Rattling

If possible, play sound through the speaker to identify any connection issues or rattling.

## 2.4 Dimensions

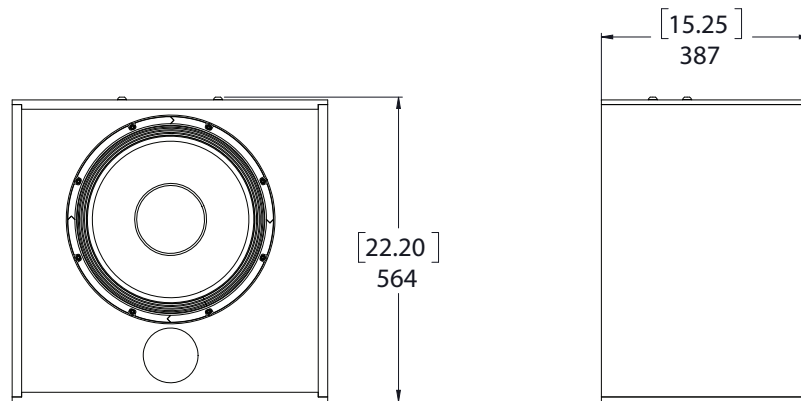

Figure 2-5 CSB115 and CSB115-CM [Inches] and Millimeters

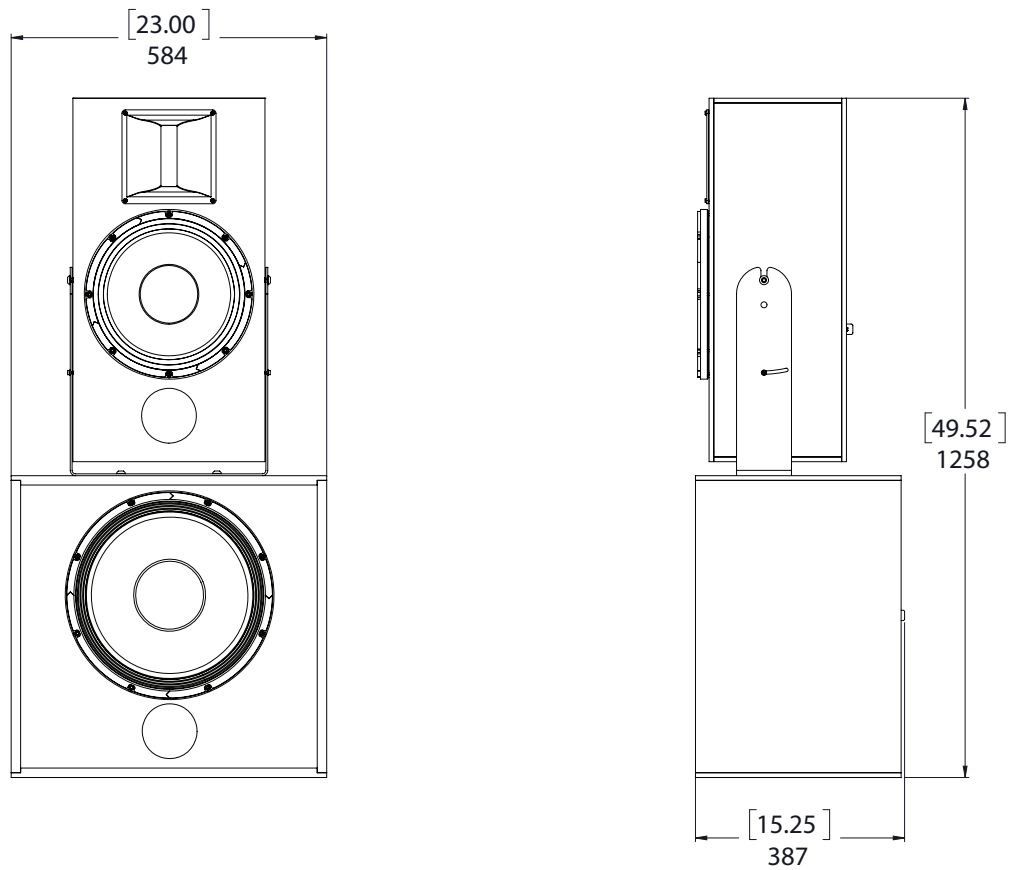

Figure 2-6 CSB115/CSB115-CM with CS50-CM (System 100A) [Inches] and Millimeters

---

---

---

# Environmental Compliance and Regulations

## A.1 EU Environmental Regulations and Compliance

Following are the CSB115 and CSB115-CM EU environmental regulations and compliance information.

### Restriction of Hazardous Substances Directive (RoHS)

All Dolby® products comply with the requirements of the EU RoHS Directive. For the Dolby Declarations of Conformity, go to <http://www.dolby.com/us/en/about/environmental-commitment.html>

### Product End-of-Life Information

This product is electronic equipment and should be disposed of in accordance with all applicable laws. Do not dispose as household waste. Do not dispose of the product in a fire. Please dispose of this product by taking it to your local electronic waste collection point or recycling center. For information regarding where to recycle electronic equipment, contact your local dealer. For additional information regarding Waste Electrical and Electronic Equipment (WEEE) and product disposal go to <http://www.dolby.com/us/en/about/environmental-commitment.html>

## A.2 Russian Environmental Regulations and Compliance

Following is the CSB115 and CSB115-CM Russian environmental compliance information.

### Restriction of Hazardous Substances (RoHS) Directive

This product complies with Russian EAC RoHS requirements.



---

---



---

# Setting System Limiters

## B.1 Setting up System Limiters

This documentation explains how to set up system limiters to protect your loudspeaker and provide maximum performance when the digital signal processor (DSP), amplifier, and loudspeaker hardware are all variables. The following procedure provides a limiter setting threshold that can protect loudspeakers in a majority of use cases. However, the speaker drivers may still be vulnerable to content issues, such as sustained feedback or large, low-frequency transients below box tuning. Good system design and common sense should be the rule.

1. Obtain an audio source (to generate pink noise) and a true RMS voltage meter with a bandwidth of at least 20 kHz that can average a reading over a period of at least 10 seconds.
2. Complete the room tuning and set the amplifier gain.  
To prevent future user error, consider setting the amplifiers at full gain, unless the amplifier gain setting is hardware or software protected. In such a case, you can optimize the amplifier gain to achieve the best signal-to-noise ratio.
3. After completing the room tuning and setting the amplifier gain, bypass the limiter on the DSP that you are using for protection, and leave all other DSP functions for that output engaged. For example, the highpass filter, crossovers, equalization, and so on.
4. Mute all system outputs except the output that is currently being calibrated.
5. Place the voltage meter across the amplifier +/- output terminals and turn up the pink noise source until the reading on the meter is slightly above the specified Threshold/RMS voltage rating for that speaker driver and its recommended processor settings (see [Section 1.3](#)).
6. Play the pink noise only long enough to obtain a stable RMS average voltage reading. For high-frequency drivers, this is typically five seconds, and for full range loudspeakers or subwoofers, it is typically ten seconds.
7. Set the limiter to a minimum ratio of 100:1, and then input the attack and release times recommended by the speaker manufacturer.
8. Engage the limiter, and decrease the threshold until the voltage is lowered to the specified rating, without changing the pink noise gain.
9. Repeat the above procedure for each driver and/or passive loudspeaker you are using.
10. If a predictive peak stop limiter is available on the DSP, engage it at 6 dB above the RMS setting.
11. Monitor for amplifier clipping. If clipping occurs during system use, lower the peak-stop threshold until the amplifier clips slightly. Alternatively, you can engage the self-contained limiter circuit in the amplifier (if it has such a limiter circuit).

You need to perform this procedure only once, as long as the combined amplifier-limiter does not change. However, amplifier gain changes modify the limiter action. If the amplifier gain is decreased, protection engages early, which limits driver output. If the amplifier gain is increased, protection engages only after the driver reading is above the safe RMS voltage.