



SLS™ CS218I-CM User's Guide

Issue 1

26 August 2020

Dolby Laboratories, Inc.

Corporate Headquarters

Dolby Laboratories, Inc.
1275 Market Street
San Francisco, CA 94103-1410 USA
Telephone 415-558-0200
Fax 415-645-4000
www.dolby.com

European Headquarters

Dolby International AB
Apollo Building, 3E
Herikerbergweg 1-35
1101 CN Amsterdam Zuidoost
The Netherlands
Telephone 31-20-651-1800
Fax 31-20-651-1801

Technical Support

Dolby Laboratories
Portal: <http://customer.dolby.com>
Email: cinemasupport@dolby.com

Region	Support Phone Numbers
Americas	+1-415-645-4900
EMEA	+44-33-0808-7700
APAC	+86-400-692-6780
Japan	+81-3-4540-6782

LIMITED WARRANTY AND WARRANTY EXCLUSIONS:

THE LIMITED WARRANTY AND WARRANTY EXCLUSIONS MAY BE FOUND AT THE FOLLOWING URL:
<https://www.dolby.com/us/en/about/warranty-and-maintenance-policies.html>.



IMPORTANT SAFETY INSTRUCTIONS



1. **INSTALLER ASSUMES ALL RESPONSIBILITY AND LIABILITY FOR THE INSTALLATION OF THESE PRODUCTS.**
2. A licensed professional engineer must approve the placement and method of attachment to the building structure prior to the installation of the system.
3. Installation must be performed by qualified, licensed, and insured installers, and installed in accordance with all laws, rules, and regulations applicable to the installation site. Failure to do so could result in serious personal injury or even death.
4. Compliance with local building codes (and, where applicable, national codes) is the responsibility of the installer. Installers should consult with local regulatory authorities for specific codes and/or guidelines for the use of this product.
5. All information presented herein is based upon materials and practices common to North America and may not directly apply to other countries because of differing material dimensions, specifications, and/or local regulations. Installers in other countries should consult with appropriate engineering and regulatory authorities for specific guidelines.
6. Use proper personal lifting techniques when working with heavy objects to avoid personal injury.
7. Any supplied rigging hardware is intended only for use with the specified loudspeaker. The installer assumes all risk of loss and/or injury arising out of the use of the supplied rigging hardware with any other rigging frame or loudspeaker.
8. This guide is meant only for the purpose of instructing the installer in the intended use of SLS supplied rigging. All other rigging is considered part of the venue and/or installer-supplied equipment and is not addressed in this guide.
9. This guide is not a comprehensive source for rigging in general. Installer assumes all responsibility for ensuring that accepted rigging and safety practices are employed. Installer assumes all responsibility for the appropriate use of SLS supplied rigging hardware and follows at a minimum all applicable laws, rules, and regulations in force for each venue.
10. The primary rigging cable for the system must be mounted to structural steel. Do not attach the primary rigging cable to any wood structure, wood roof joists, or wood frame. In all instances, the primary rigging cable and its attachment point must be mounted in a way that supports a minimum of five times the static weight of the system, or greater if a higher requirement is mandated per local laws.
11. A system safety cable must be utilized that uses a different mount point to structural steel than the primary rigging cable. The system safety cable must be mounted to structural steel in a way that does not cause a pendulum swing that would allow the system to contact the building structure, rigging, or other equipment in the event of a primary rigging failure. The safety cable must be installed so that there is no slack. A safety cable with slack can cause a severe shock load to the cable and mounting points and result in a primary rigging failure. Do not attach the system safety cable to any wood structure, wood roof joists, or wood frame. In all instances, the safety cable must be mounted in a way that supports a minimum of five times the static weight of the system, or greater if a higher requirement is mandated per local laws.
12. For ceiling installations, the system safety cable must be mounted to the structural steel above the suspended ceiling tile in an auditorium. For wall installations, the system safety cable must be anchored to the building structure independent of the primary rigging device.

13. Do not install on a structure that is prone to abnormal vibration, movement, or chance of impact. Failure to do so could result in damage to the equipment and/or damage to the mounting surface.
14. Make sure that no water pipes, natural gas lines, electrical wire, or conduit are present where the speaker is to be installed. Cutting or drilling into water pipes, natural gas lines, electrical wire, or conduit could cause serious personal injury or property damage.
15. Prior to suspending any system, always inspect all components (enclosures, rigging frames, pins, eyebolts, track fittings, and so on) for cracks, deformations, corrosion, and missing, loose, or damaged parts that could reduce the strength and safety of the system. Do not suspend the system until the proper corrective action has been taken.
16. No open flame sources should be placed on or near the apparatus. Do not install near any heat sources such as radiators, heat registers, stoves, or other apparatus that produces heat.
17. Only clean product with a dry or damp cloth.
18. Do not block any ventilation openings.
19. Hearing damage may result from prolonged exposure to excessive sound pressure levels (SPL). The loudspeaker is easily capable of generating SPL sufficient to cause permanent hearing damage to performers, production crew, and audience members. Caution should be taken to avoid prolonged exposure to SPL in excess of 90 dB.
20. The products covered by this manual are not intended for use in rain or high-moisture environments. Moisture can damage the product and cause corrosion of electrical contacts and metal parts. Premature product failure or serious personal injury could occur if this product is used outdoors or in wet indoor environments. Keep speakers out of extended or intense direct sunlight.
21. The loudspeaker can generate considerable acoustical energy and may move during use. The system must be mounted in a way that allows sufficient clearance for this movement without risk of contact with the building structure, rigging, or other equipment. Installer-supplied hardware must be intended for overhead suspension and comply with ASME B30.20 and be manufactured under product traceability controls. Compliant hardware will be referenced with a working load limit (WLL) and a traceability code. The hardware must be load rated to support a minimum of five times the static weight of the system, or greater if a higher requirement is mandated per local laws. Generally, this type of hardware is available from rigging supply houses, industrial supply catalogs, and specialized rigging distributors. Local hardware stores do not usually stock these products.
22. Installed systems should be inspected at least annually or as required by local laws. The inspection shall include a visual survey of all corners and load-bearing surfaces for signs of cracking, water damage, delamination, or any other condition that may decrease the strength of the rigging frame and speakers. The rigging hardware must be inspected for fatigue at least annually or as required by local laws. The inspection shall include a visual survey of the hardware for signs of corrosion, bending, or any other condition that may decrease the strength of the hardware.
23. Prior to suspending the system, an expert who is trained and experienced in suspending speaker systems should inspect all parts and components. Dolby is not responsible for the application of its products for any purpose or the misuse of this information for any purpose. Furthermore, Dolby is not responsible for the abuse of its products caused by avoiding compliance with inspection and maintenance procedures or any other abuse.

Table of Contents

Chapter 1 Introduction	1
1.1 CS218I-CM Overview	1
1.2 CS218I-CM Specifications.....	1
1.3 CS218i-CM Processor Settings.....	2
Chapter 2 Installing the SLS CS218I-CM	3
2.1 Rigging the CS218I-CM for Overhead Installations.....	3
2.1.1 Tools Required.....	3
2.1.2 Installing the CS218I-CM.....	3
2.1.3 Connecting the Safety Cable	4
2.2 Connecting Audio	4
2.3 Finalizing the Installation	5
2.4 Dimensions.....	5
Appendix A Environmental Compliance and Regulations.....	7
A.1 EU Environmental Regulations and Compliance.....	7
A.2 Russian Environmental Regulations and Compliance.....	7
Appendix B Setting System Limiters	9
B.1 Setting up System Limiters	9

Introduction

1.1 CS218I-CM Overview

The SLS™ CS218I-CM is a high-performance flyable subwoofer for use in cinema auditoriums and professional applications. The unit contains 24 M10 rigging points at convenient locations around the loudspeaker. For mounting to the building structure, you can attach rigging hardware, as described in [Section 2.1](#).



Figure 1-1 CS218I-CM

1.2 CS218I-CM Specifications

Following are the CS218I-CM general specifications:*

- Frequency response: 29 Hz to 300 Hz
- Sensitivity: 1 watt @ 1 M: 102 dB
- Nominal impedance: 4 ohms
- Continuous power rating: 1,200 watts
- Maximum continuous rated SPL at 1 meter: 133 dB
- Coverage angle: Omnidirectional
- Drivers: Dual 18-inch low frequency
- Barrier strip: Accepts 16- to 12-gauge wire
- Size:
 - Width: 48 inches (1,219 millimeters)
 - Height 30 inches (762 millimeters)
 - Depth: 25 inches (636 millimeters)
- Net weight: 136 pounds (61.69 kilograms)
- Shipping weight: 168 pounds (76.2 kilograms)

* SLS Audio reserves the right to make changes to existing products without notice.

1.3 CS218I-CM Processor Settings

Following are the CS218I-CM processor settings:

Crossover Section	Frequency	Slope
Highpass filter	26 Hz	12 dB octave (second order) Butterworth
Lowpass filter	80–300 Hz	24 dB octave (fourth order) Butterworth

Limiting Section	Threshold/RMS Voltage	Attack	Release	Peak Stop Voltage
See Appendix B	64 V	45 ms	720 ms	126 V

Installing the SLS CS218I-CM

2.1 Rigging the CS218I-CM for Overhead Installations

The CS218I-CM provides 24 rigging points to attach user-supplied rigging hardware.



Warning: CONSULT A PROFESSIONAL MECHANICAL OR STRUCTURAL ENGINEER TO APPROVE ALL ATTACHMENTS TO BUILDING STRUCTURE. THIS APPARATUS MUST BE INSTALLED BY LICENSED PROFESSIONAL INSTALLERS. IF NOT INSTALLED ON THE BUILDING STRUCTURE PROPERLY, THIS APPARATUS COULD FALL, CAUSING PERSONAL INJURY OR DEATH. SUSPENSION OF HARDWARE COMPONENTS MUST BE CALCULATED WITH A GIVEN SAFETY FACTOR TO BE WITHIN THEIR RESPECTIVE WORKING LOAD LIMITS. INSPECT ALL COMPONENTS BEFORE INSTALLATION. ALL LOCAL BUILDING AND SEISMIC CODES MUST BE ADHERED TO.

2.1.1 Tools Required

- 6 mm Allen wrench to remove the existing bolts. After removal, you can attach user-supplied rigging hardware to the available M10 installation points.
- #2 Phillips screwdriver for attaching speaker wire to the barrier strip.

2.1.2 Installing the CS218I-CM

Safe overhead rigging practices require an understanding of the proper methods and are outside the scope of this guide. All user-supplied rigging hardware must have a minimum 5:1 safety factor, based on the weight of the CS218I-CM. You should use only the four attachment points facing the hanging surface.



Warning: THE THREADS OF M10 USER-SUPPLIED RIGGING HARDWARE THAT ATTACH TO THE APPARATUS MUST EXTEND A MINIMUM OF 1.25-INCHES (31.8 mm) INTO THE CABINET BUT NOT EXCEED 2.25-INCHES (57.2 mm). HARDWARE MUST HAVE A 5:1 SAFETY FACTOR, OR GREATER IF A HIGHER REQUIREMENT IS MANDATED PER LOCAL LAWS. THE M10 INSERTS ON THE CABINET SIDES SHOULD NOT BE USED FOR EYEBOLTS THAT PULL AT AN ANGLE GREATER THAN 45 DEGREES TO THE LOAD. HARDWARE MUST BE SECURELY TIGHTENED AND THE WEIGHT EVENLY DISTRIBUTED THROUGH THE FOUR ATTACHMENT POINTS.

The following figure shows examples of the CS218I-CM rigging points and flying options.

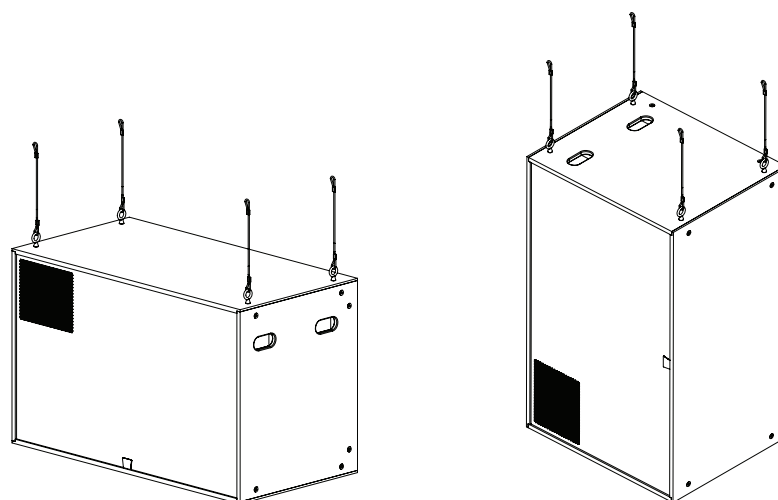

Figure 2-1 Rigging Points and Flying Options

2.1.3 Connecting the Safety Cable

After attaching the CS218I-CM to the building structure, you must connect a secondary safety attachment point to an independent point on the building structure. Any of the unused M10 rigging points are available for attaching an installer-supplied safety cable. Based on the weight of the CS218I-CM, all installer-supplied safety rigging hardware must have a minimum 5:1 safety factor, or greater if a higher requirement is mandated per local laws. Remove all slack to avoid any shock loading of the cable in case of a primary rigging failure.



Warning: INSTALLER-SUPPLIED RIGGING HARDWARE MUST HAVE A MINIMUM 5:1 SAFETY FACTOR BASED ON THE WEIGHT OF THE APPARATUS. YOU MUST SECURELY TIGHTEN THE HARDWARE. REMOVE ALL SLACK FROM THE CABLE. REPLACE THE CABLE IF IT HAS BEEN PULLED DUE TO A PRIMARY RIGGING FAILURE.

2.2 Connecting Audio

The input barrier strip accepts 16- to 12-gauge wire, with either #6 spade lugs or bare wire. Always use industry-standard practices for selecting wire gauge, based on the product power rating and cable length. Note that the barrier strip is marked with a plus (+) or red indicator to show the polarity. Per IEC standard, a positive voltage on the positive marked input results in the low-frequency drivers moving outward. Always tie down the cable to available hardware to minimize any buzzing or pullouts.



Warning: TURN OFF ALL AMPLIFIERS WHEN CONNECTING THE LOUDSPEAKER WIRING.

2.3 Finalizing the Installation

- Make sure that the audio wiring is secure and that vibration from the speaker does not cause any buzzing or rattling.
- Check any hanging rigging for slack.
- Check the safety cable to ensure there is no slack, rubbing, buzzing, or rattling, and that the safety cable cannot short out exposed speaker wiring.
- If possible, play sound through the speaker to identify any connection issues, buzzing, rattling, or vibrations.

2.4 Dimensions

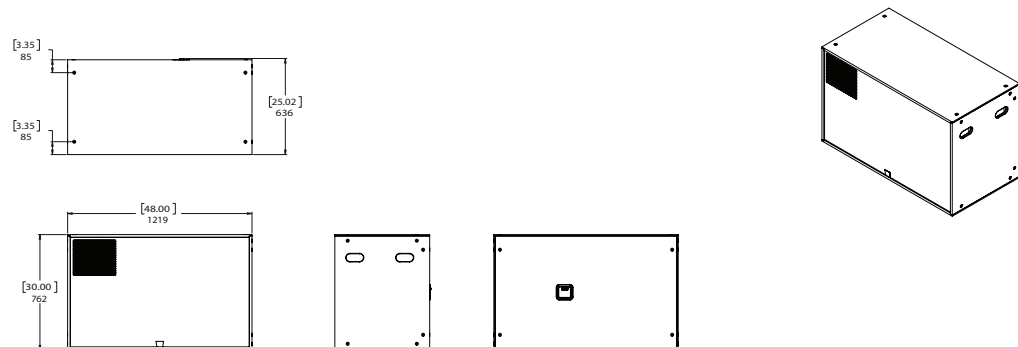

Figure 2-2 Dimensions in [Inches] and Millimeters

Environmental Compliance and Regulations

A.1 EU Environmental Regulations and Compliance

Following are the CS218I-CM EU environmental regulations and compliance information.

Restriction of Hazardous Substances Directive (RoHS)

All Dolby® products comply with the requirements of the EU RoHS Directive. For the Dolby Declarations of Conformity, go to

<http://www.dolby.com/us/en/about/environmental-commitment.html>

Product End-of-Life Information

This product is electronic equipment and should be disposed of in accordance with all applicable laws. Do not dispose as household waste. Do not dispose of the product in a fire. Please dispose of this product by taking it to your local electronic waste collection point or recycling center. For information regarding where to recycle electronic equipment, contact your local dealer. For additional information regarding Waste Electrical and Electronic Equipment (WEEE) and product disposal go to

<http://www.dolby.com/us/en/about/environmental-commitment.html>

A.2 Russian Environmental Regulations and Compliance

Following is the CS218I-CM Russian environmental compliance information.

Restriction of Hazardous Substances (RoHS) Directive

This product complies with Russian EAC RoHS requirements.



Setting System Limiters

B.1 Setting up System Limiters

This documentation explains how to set up system limiters to protect your loudspeaker and provide maximum performance when the digital signal processor (DSP), amplifier, and loudspeaker hardware are all variables. The following procedure provides a limiter setting threshold that can protect loudspeakers in a majority of use cases. However, the speaker drivers may still be vulnerable to content issues, such as sustained feedback or large, low-frequency transients below box tuning. Good system design and common sense should be the rule.

1. Obtain an audio source (to generate pink noise) and a true RMS voltage meter with a bandwidth of at least 20 kHz that can average a reading over a period of at least 10 seconds.
2. Complete the room tuning and set the amplifier gain.
To prevent future user error, consider setting the amplifiers at full gain, unless the amplifier gain setting is hardware or software protected. In such a case, you can optimize the amplifier gain to achieve the best signal-to-noise ratio.
3. After completing the room tuning and setting the amplifier gain, bypass the limiter on the DSP that you are using for protection, and leave all other DSP functions for that output engaged. For example, the highpass filter, crossovers, equalization, and so on.
4. Mute all system outputs except the output that is currently being calibrated.
5. Place the voltage meter across the amplifier +/- output terminals and turn up the pink noise source until the reading on the meter is slightly above the specified Threshold/RMS voltage rating for that speaker driver and its recommended processor settings (see [Section 1.3](#)).
6. Play the pink noise only long enough to obtain a stable RMS average voltage reading. For high-frequency drivers, this is typically five seconds, and for full range loudspeakers or subwoofers, it is typically ten seconds.
7. Set the limiter to a minimum ratio of 100:1, and then input the attack and release times recommended by the speaker manufacturer.
8. Engage the limiter, and decrease the threshold until the voltage is lowered to the specified rating, without changing the pink noise gain.
9. Repeat the above procedure for each driver and/or passive loudspeaker you are using.
10. If a predictive peak stop limiter is available on the DSP, engage it at 6 dB above the RMS setting.
11. Monitor for amplifier clipping. If clipping occurs during system use, lower the peak-stop threshold until the amplifier clips slightly. Alternatively, you can engage the self-contained limiter circuit in the amplifier (if it has such a limiter circuit).
You need to perform this procedure only once, as long as the combined amplifier-limiter does not change. However, amplifier gain changes modify the limiter action. If the amplifier gain is decreased, protection engages early, which limits driver output. If the amplifier gain is increased, protection engages only after the driver reading is above the safe RMS voltage.