



Dolby DSR1260/DSR1280

Owner's Manual

1 January 2024
8800294 Issue 2

Notices

Copyright

© 2022-2024 Dolby Laboratories, Inc. All rights reserved.

Dolby Laboratories, Inc.

1275 Market Street
San Francisco, CA 94103-1410 USA
Telephone 415-558-0200
Fax 415-645-4000
<http://www.dolby.com>

Trademarks

Dolby and the double-D symbol are registered trademarks of Dolby Laboratories, Inc.

The following are trademarks of Dolby Laboratories, Inc.

Dialogue Intelligence™	Dolby Theatre®
Dolby®	Dolby Vision®
Dolby Advanced Audio™	Dolby Vision IQ®
Dolby Atmos®	Dolby Voice®
Dolby Audio®	Feel Every Dimension®
Dolby Cinema®	Feel Every Dimension in Dolby™
Dolby Digital Plus®	Feel Every Dimension in Dolby Atmos™
Dolby Digital Plus Advanced Audio™	MLP Lossless™
Dolby Digital Plus Home Theater™	Pro Logic®
Dolby Home Theater®	Surround EX™

All other trademarks remain the property of their respective owners.

Product model

This documentation applies to: Dolby DSR1260 & Dolby DSR1280 (Model: CID1031).

Limited warranty and warranty exclusions

THE LIMITED WARRANTY AND WARRANTY EXCLUSIONS MAY BE FOUND AT THE FOLLOWING URL: <http://www.dolby.com/us/en/about/warranty-and-maintenance-policies.html>

Contents

1	Important safety and regulatory information.....	4
2	Introduction to the Dolby speaker DSR1260/DSR1280.....	7
2.1	About this documentation.....	9
2.2	Dolby DSR1260/DSR1280 key features and benefits.	9
2.3	Dolby DSR1260/DSR1280 design simulations.....	9
2.4	General room placement.....	11
2.5	General information about the Dolby DSR1260/DSR1280.....	11
2.5.1	Placement of the Dolby DSR1260/DSR1280 on a wall or ceiling.....	11
2.5.2	Determining proper horizontal aiming for the side and rear surround loudspeakers.....	11
2.5.3	Side and rear surround vertical aiming.....	12
2.5.4	Top surround position.	13
2.6	Selecting brackets and yokes.....	14
2.7	Dolby DSR1260/DSR1280 wire selection.....	14
2.8	Contacting Dolby	14
3	Assembling, installing, and aiming the Dolby DSR1260/DSR1280.....	16
3.1	Horn rotation on the Dolby DSR1260/DSR1280.....	17
3.1.1	Rotating the horn on the Dolby DSR1260/DSR1280.....	18
3.2	Installing brackets.....	20
3.3	Installing a yoke.....	21
3.4	Aiming the Dolby DSR1260/DSR1280 using a laser.....	22
3.4.1	Using a laser for horizontal aiming.....	22
3.4.2	Using a laser for vertical aiming.....	23
3.5	Installing the safety cable.....	23
3.6	Connecting the Dolby DSR1260/DSR1280.....	25
4	Dolby DSR1260/DSR1280 specifications.....	27
4.1	Dolby DSR1260 specifications.....	28
4.2	Dolby DSR1280 specifications.....	29
4.3	Dolby DSR1260/DSR1280 dimensions.....	31
5	Dolby DSR1260/DSR1280 signal processing.....	33
5.1	Dolby DSR1260 signal processing.....	34
5.2	Dolby DSR1280 signal processing.....	34
6	System limiters.....	36
6.1	Setting system limiters.....	37
7	Documentation revision history.....	38

Important safety and regulatory information



Safety

INSTALLER ASSUMES ALL RESPONSIBILITY AND LIABILITY FOR THE INSTALLATION OF THIS PRODUCT.

No information contained in this guide is intended as a warranty on the part of Dolby. Anyone using this information assumes all liability arising from its use. Product abuse, use of the product not in accordance with Dolby instructions, or use in an application for which the product has not been designed is not covered under any Dolby warranty, nor is Dolby liable for any loss or damage.

Installation must be performed by qualified, licensed, and insured installers, and installed in accordance with all laws, rules, and regulations applicable to the installation site. Failure to do so could result in serious personal injury or even death. Prior to installing this product, read and completely understand the installation instructions. You must read these instructions to prevent personal injury and property damage. Keep the installation instructions in an easily accessible location for future reference.

A licensed professional engineer must approve the placement and method of attachment to the building structure prior to the installation of the system.

All information presented herein is based upon materials and practices common to North America and may not directly apply to other countries because of differing material dimensions, specifications, and/or local regulations. Installers in other countries should consult with appropriate engineering and regulatory authorities for specific guidelines.

Any supplied rigging hardware is intended only for use with the specified loudspeaker(s). The installer assumes all risk of loss and/or injury arising out of the use of the supplied rigging hardware with any other loudspeaker. All other rigging is considered part of the venue and/or installer-supplied equipment and is not addressed in this guide. This guide is not a comprehensive source for rigging in general. Installer assumes all responsibility for ensuring that accepted rigging and safety practices are employed. Installer assumes all responsibility for the appropriate use of Dolby supplied rigging hardware and follows at a minimum all applicable laws, rules, and regulations in force for each venue.

Make sure that no water pipes, natural gas lines, electrical wire, or conduit are present where the speaker is to be installed. Cutting or drilling into water pipes, natural gas lines, electrical wire, or conduit could cause serious personal injury or property damage.

Dolby is not responsible for the application of its products for any purpose or the misuse of this information for any purpose. Furthermore, Dolby is not responsible for the abuse of its products caused by avoiding compliance with inspection and maintenance procedures or any other abuse.

Proper selection of mounting hardware is not included; proper assembly and installation of mounting hardware, including, but not limited to, selection of appropriate weight-bearing support and bracket use, are the exclusive responsibility of the installer. Dolby disclaims any liability, including damage or injury, for the use of mounting hardware supplied by any party other than Dolby. Any modification to

the speaker system hardware provided by Dolby (for example, mounting by drilling holes into the speaker system) will render the product warranty null and void.



Caution: Use proper lifting techniques when working with heavy objects to avoid personal injury.

No open flame sources should be placed on or near the apparatus. Do not install near any heat sources such as radiators, heat registers, stoves, or other equipment that produces heat.

Storage temperature: -4 to +140°F (-20 to +60°C). The products covered by this manual are not intended for use in high-moisture environments. Moisture can damage the product and cause corrosion of electrical contacts and metal parts. Avoid exposing the speakers to direct moisture. Keep speakers out of extended or intense direct sunlight. Premature product failure or serious personal injury could occur if this product is used outdoors or in wet indoor environments.



High temperature warning: Loudspeaker system may reach elevated temperatures during operation. Always remove all drive signals and allow ample time for the system to cool down prior to handling.

Hearing damage can occur by prolonged exposure to excessive sound pressure level (SPL); the loudspeaker is easily capable of generating SPL sufficient to cause permanent hearing damage to performers, production crew, or audience members. Caution should be taken to avoid prolonged exposure to SPL in excess of 90 dB.

This product is intended for indoor use only.

Clean the metal frame and chassis only with a dry cloth.

Do not block any ventilation openings. Install in accordance with the instructions as detailed in this manual and the Product Information document.

Do not install near any heat sources, such as radiators, heat registers, stoves, or other apparatus (including amplifiers) that produce heat.

When a rolling cart is used, use caution when moving the cart/apparatus combination to avoid injury.

Refer all servicing to qualified service personnel. Servicing is required when the apparatus has been damaged in any way.

This product may require installation in a restricted access location. Please refer to this manual and to the Product Information document.

Warning:



To reduce electric shock, do not expose the apparatus to dripping or splashing; no objects filled with liquids, such as mugs, shall be placed on the apparatus.

Caution:



Troubleshooting must be performed by a trained electrician. To reduce the risk of electric shock, do not attempt to service this equipment unless you are qualified to do so.

SAFETY SYMBOL KEY**Caution:**

This symbol that appears on the unit and/or instruction manual is intended to alert the user to the presence of important safety operating and maintenance instructions.

Warning:

This symbol that appears on the unit and/or instruction manual is intended to alert the user to the presence of uninsulated "dangerous" voltage within the product's enclosure that may be of sufficient magnitude to constitute a risk of electric shock to persons.

High temperature warning:

This symbol that appears on the unit and/or the instruction manual is intended to alert the user that the item can be hot and that care must be taken accordingly.

EU Environmental regulations/ compliance and product disposal information

Restriction of Hazardous Substances Directive (RoHS): All Dolby products comply with the requirements of the EU RoHS Directive. This product is electronic equipment and should be disposed of in accordance with all applicable laws.

Do not dispose as household waste. Do not dispose of the product in a fire. Please dispose of this product by taking it to your local electronic waste collection point or recycling center. For information regarding where to recycle electronic equipment, contact your local dealer. For additional information regarding Waste Electrical and Electronic Equipment (WEEE) and product disposal go to <http://dolby.com/us/en/about/environmental-commitment.html>.

EAC RoHS information

Product Model CID1031 complies with EAC RoHS requirements.



Introduction to the Dolby speaker DSR1260/DSR1280

The Dolby DSR1260/DSR1280 speakers are high-performance cinema surround loudspeakers for use in 5.1 and Dolby Surround 7.1 cinema auditoriums, as well as medium to large-size Dolby Atmos equipped auditoriums. They share the same asymmetrical waveguide technology as the rest of the Dolby loudspeaker family, which provides superior audience coverage. The Dolby DSR1260/DSR1280 speakers provide two coverage pattern options, allowing optimized performance for wall or ceiling surround applications. The Dolby DSR1260, typically used for wall installations, features a 60° vertical dispersion pattern and an asymmetrical horizontal dispersion pattern of 60° at the top and 120° at the bottom. The Dolby DSR1280, typically used for overhead installations, features an 80° vertical dispersion pattern and an asymmetrical horizontal dispersion pattern of 80° at the top and 130° at the bottom. Additionally, the high-frequency horns within the Dolby DSR1260/DSR1280 can be rotated, providing the same great coverage regardless of loudspeaker orientation.

The Dolby DSR1260 and DSR1280 utilize a high-performance, high-output 12" low-frequency driver and a 1" exit compression driver. Both transducers are FEM (finite element modeling) optimized and utilize state-of-the-art materials, allowing them to deliver high sound pressure levels with minimal distortion. These advanced drivers, coupled with Dolby industry-leading system design and support philosophy, allow for exceptional performance, as well as quick, easy installation and service.

Figure 1: Dolby DSR1260/DSR1280 front (top)

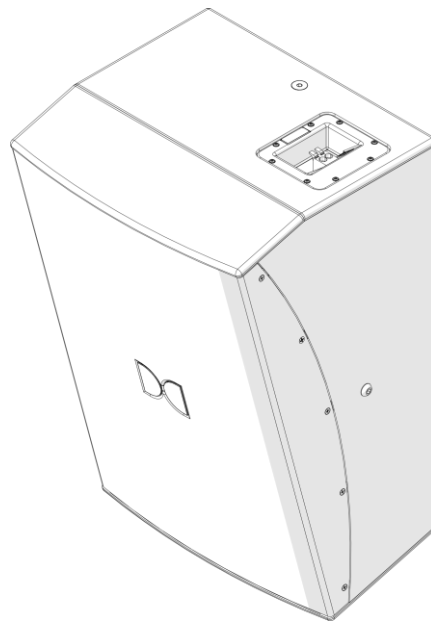

The list below is an outline of this chapter:

- [About this documentation](#)
- [Dolby DSR1260/DSR1280 key features and benefits](#)
- [Dolby DSR1260/DSR1280 design simulations](#)
- [General room placement](#)
- [General information about the Dolby DSR1260/DSR1280](#)
- [Selecting brackets and yokes](#)

- [Dolby DSR1260/DSR1280 wire selection](#)
- [Contacting Dolby](#)

2.1 About this documentation

This documentation shows you key features and benefits of the Dolby DSR1260/DSR1280 speakers and how to install the system in a typical cinematic exhibition environment.

2.2 Dolby DSR1260/DSR1280 key features and benefits

The Dolby DSR1260 and DSR1280 speakers each feature an asymmetrical high-frequency horn coupled with a high-performance transducer. This configuration yields superior audience coverage, as well as amplitude control between near and far listeners.

- The patented asymmetrical high-frequency horn design provides long-distance coverage from the top of the horn, while the bottom of the horn provides wider coverage and volume shading for the audience closer to the loudspeaker. This provides greatly improved coverage for the entire auditorium in comparison to conventional horn designs.
- The advanced input plate features a high-current, spring-loaded terminal block that enables quick installation without the need for spade lugs or a crimping tool.
- The high-frequency driver is a very low-distortion 44.4 mm polyimide dome with a frequency response up to 20 kHz.
- The low-frequency driver is a 12" transducer with FEM (finite element modeling) optimized motor and suspension, optimized cooling for low power compression and a high excursion rating.
- The two positions of the industry-standard four-hole mounting on the rear of the enclosure allow for minimizing speaker protrusion into the projector light path when aiming the speaker. They can also provide flexibility in mounting.

Figure 2: Dolby DSR1260 horn coverage

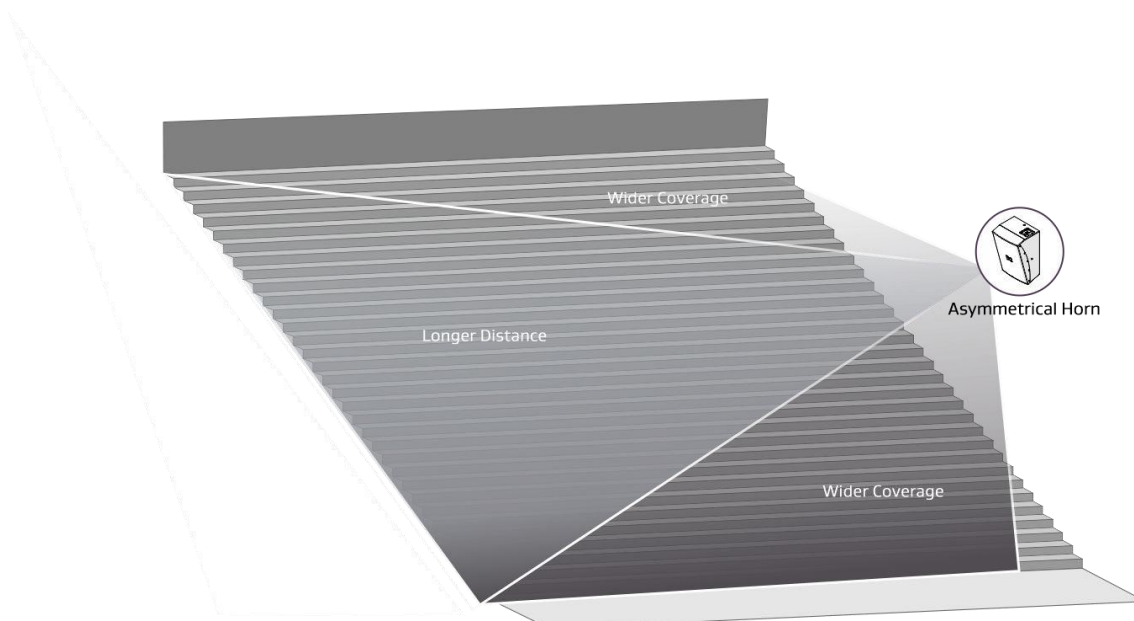

2.3 Dolby DSR1260/DSR1280 design simulations

The Dolby DSR1260/DSR1280 uses GLL format files for software simulation modeling.

The GLL files are used to simulate the DSR1260/DSR1280 in an acoustical simulation software. You can download the GLL files at <https://professional.dolby.com/product/cinema-audio-products/DSR1280-DSR1260/>

To run the GLL files, use EASE or EASE Focus software. The software can be downloaded from: <https://focus.afmg.eu/index.php/fc-downloads-en.html>.



Note: While the Dolby DSR1260 is commonly used for sidewalls, and the DSR1280 for overheads, Dolby provides simulations for both speakers in both positions to meet the needs of an installation.

Dolby DSR1260 GLL

There are two GLL files for the DSR1260. The “DSR1260 Sidewall” is for sidewall simulations only. The zero-degree vertical aiming reference is the back of the enclosure, thus the polar has a built-in 15-degree downward angle from the transducers. The “DSR1260 Overhead” GLL polar references the zero-degree vertical aiming reference to the front of the enclosure, so the transducers directly point where the GLL is aimed. The overhead polar was measured with the enclosure rotated 90 degrees counterclockwise (low-frequency horn on the right when looking at the front of the enclosure), and the horn rotated 90 degrees clockwise such that the top horizontal of the coverage pattern is still at the top of the rotated enclosure. When used in the room model, the top horizontal should always be closest to the ceiling no matter the box aiming. In the actual installation, the horn can be rotated such that the enclosure can be mirrored for the two overhead rows.

Dolby DSR1280 GLL

There are two GLL files for the DSR1280. The “DSR1280 Sidewall” is for sidewall simulations only. The zero-degree vertical aiming reference is the back of the enclosure, thus the polar has a built-in 15-degree downward angle from the transducers. The “DSR1280 Overhead” GLL polar references the zero-degree vertical aiming reference to the front of the enclosure, so the transducers directly point where the GLL is aimed. The overhead polar was measured with the enclosure rotated 90 degrees counterclockwise (LF on right when looking at the front of the enclosure) and the horn rotated 90 degrees clockwise such that the top horizontal of the coverage pattern is still at the top of the rotated enclosure. When used in the room model, the top horizontal should always be closest to the ceiling regardless of the angle of the enclosure. In the actual installation, the horn can be rotated such that the enclosure can be mirrored for the two overhead rows.

Figure 3: Dolby DSR1260 shown for reference

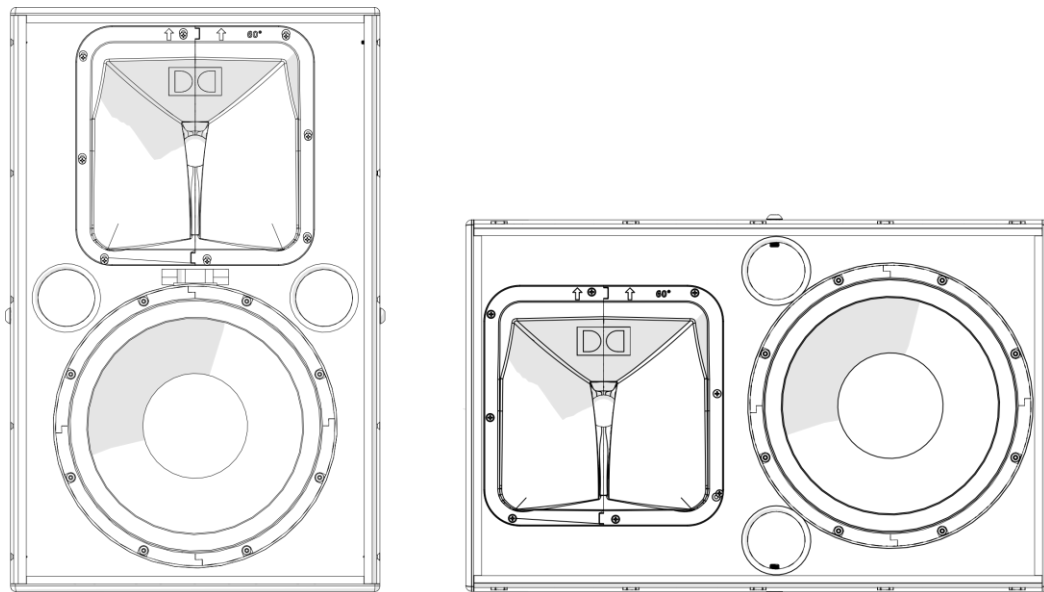

2.4 General room placement

This section provides information on the placement of the Dolby DSR1260/DSR1280 in a standard auditorium and in an auditorium equipped with Dolby Atmos.

Figure 4: Standard auditorium example

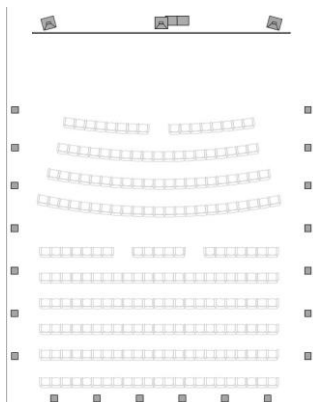
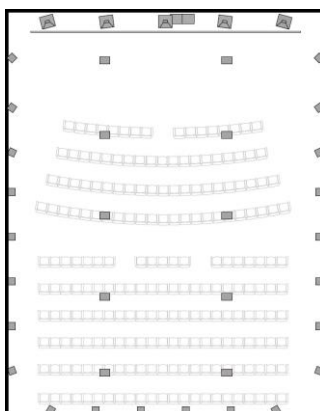

Figure 5: Dolby Atmos equipped auditorium example



2.5 General information about the Dolby DSR1260/DSR1280

Use the information provided in this section to aim the Dolby DSR1260/DSR1280 for precise sound distribution.

2.5.1 Placement of the Dolby DSR1260/DSR1280 on a wall or ceiling

The Dolby DSR1260/DSR1280 can be attached to a wall or ceiling. For 5.1 or Dolby Surround 7.1 rooms, you should follow common industry practices on speaker placement and aiming. For Dolby Atmos rooms, follow the Dolby Atmos Specification Guide, which can be found here: <https://professional.dolby.com/siteassets/cinema-products--documents/dolby-atmos-specifications.pdf>.

2.5.2 Determining proper horizontal aiming for the side and rear surround loudspeakers

For 5.1 and Dolby Surround 7.1 installations, the side and rear surrounds do not have a horizontal angling requirement where speakers point toward the central listening area (CLA).

For Dolby Atmos installations, to determine the proper horizontal aiming for the side- and rear-surround loudspeakers, define a rectangle in the CLA.

Side and rear surround loudspeakers adjacent to the central listening area must aim directly into the auditorium (that is, 0° from perpendicular), $\pm 10^\circ$.

For installations that utilize loudspeaker pairing, splaying the paired loudspeakers will improve sound coverage. For all loudspeaker pairs, we recommend these aiming parameters, based on the CLA:

- Aim the forward paired loudspeaker to the near-side forward corner.
- Aim the rearward paired loudspeaker to the near-side rear corner.

Figure 6: Horizontal aiming for side and rear surround

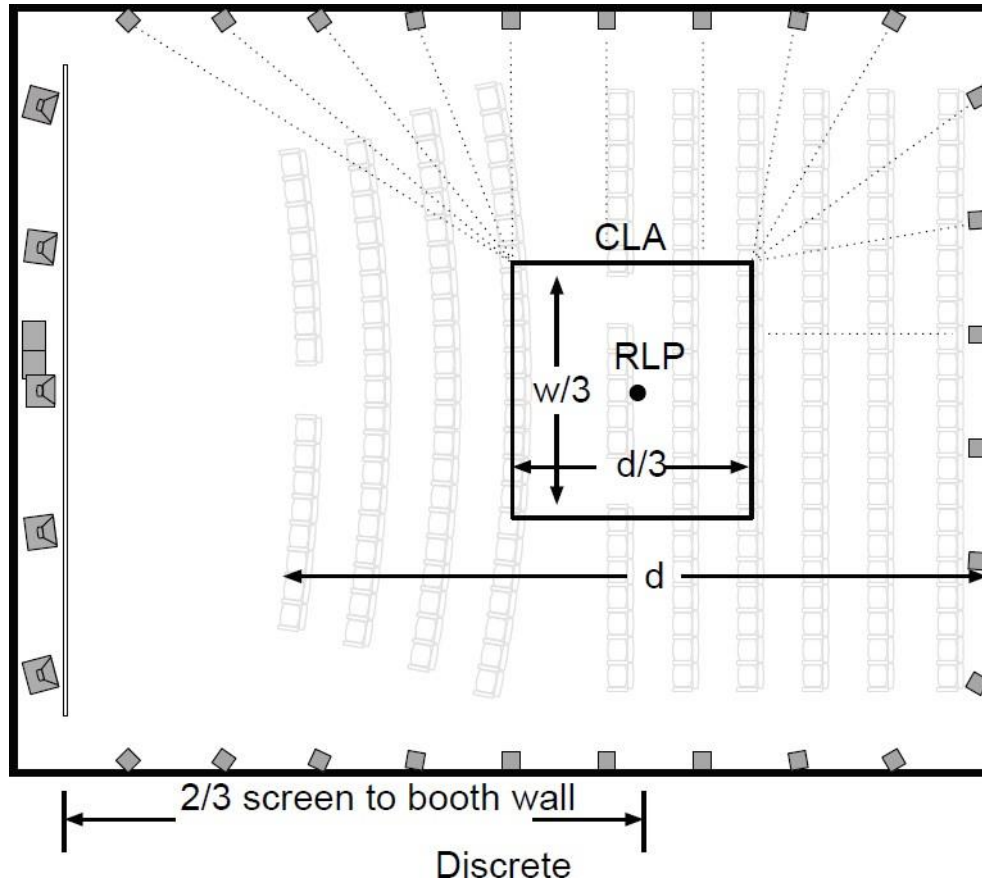

2.5.3 Side and rear surround vertical aiming

Side-and rear-surround loudspeakers should be tilted vertically to orient the axis of each loudspeaker to the ear height of a seated listener in the farthest seat. The loudspeaker can be aimed higher, but not by more than half the loudspeaker vertical coverage angle. Typically, rear-surround loudspeakers should all have the same downward tilt. The tilt of the side-surround loudspeakers should not change abruptly ($>10^\circ$) from speaker to speaker along the array.

Figure 7: Side and rear vertical surround aiming example

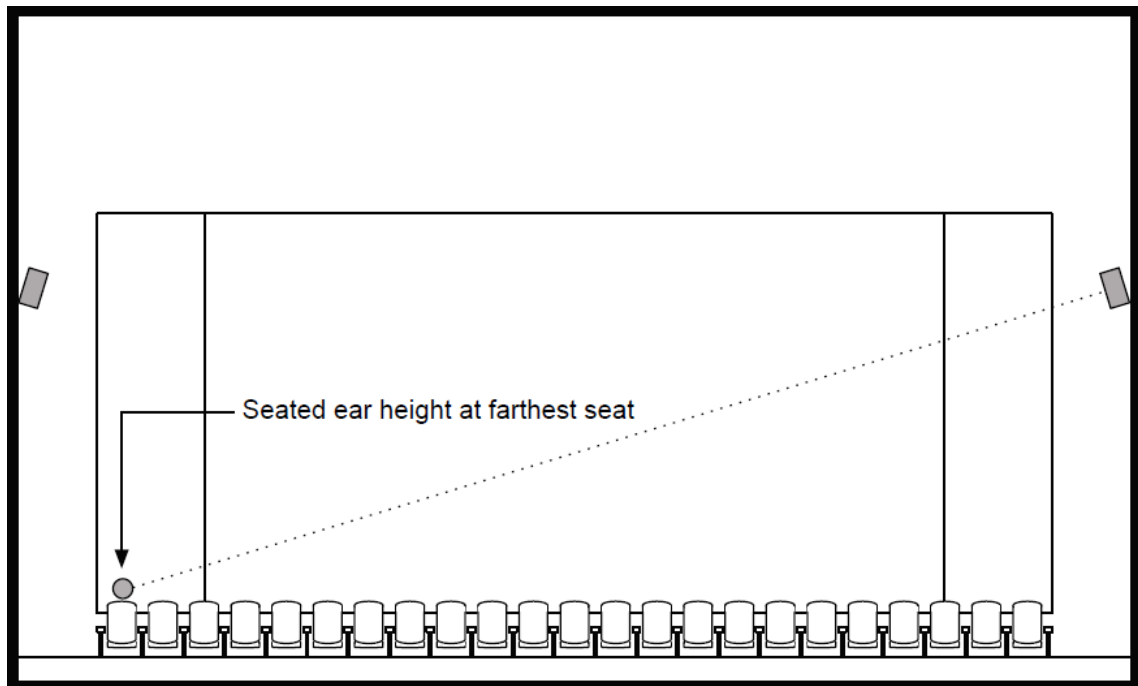

2.5.4 Top surround position

Top-surround loudspeakers must always be placed as left/right pairs, with the left loudspeaker and right loudspeaker at the same distance from the front wall.

The top-surround loudspeaker pairs must be placed symmetrically with respect to the screen center line. The top-surround arrays should typically be placed in line with the left-center and right-center screen loudspeakers.

We recommend wider spacing for tall auditoriums, which is also acceptable for typical auditoriums when standard placement is unachievable. The maximum width between top-surround loudspeakers should then be determined by elevation angles as follows (See Figure 8): Let E be the elevation angle of the nearest side-surround loudspeaker measured from the RLP. The elevation angle of the corresponding top-surround array should be greater than or equal to 45 degrees plus half of angle E . For example, if E is 20 degrees, then the elevation angle of the top-surround array should be greater than or equal to 55 degrees.

If there is no side-surround loudspeaker directly adjacent to the RLP, or it is unclear which loudspeaker to reference, it is acceptable to take angle E from the midpoint between two side-surround loudspeakers, one that is slightly in front of and one slightly behind the RLP. Likewise, for the top-surround elevation angle, 45 degrees $+E/2$, an interpolated point between two top-surround loudspeakers can be used.

Figure 8: Top surround position example

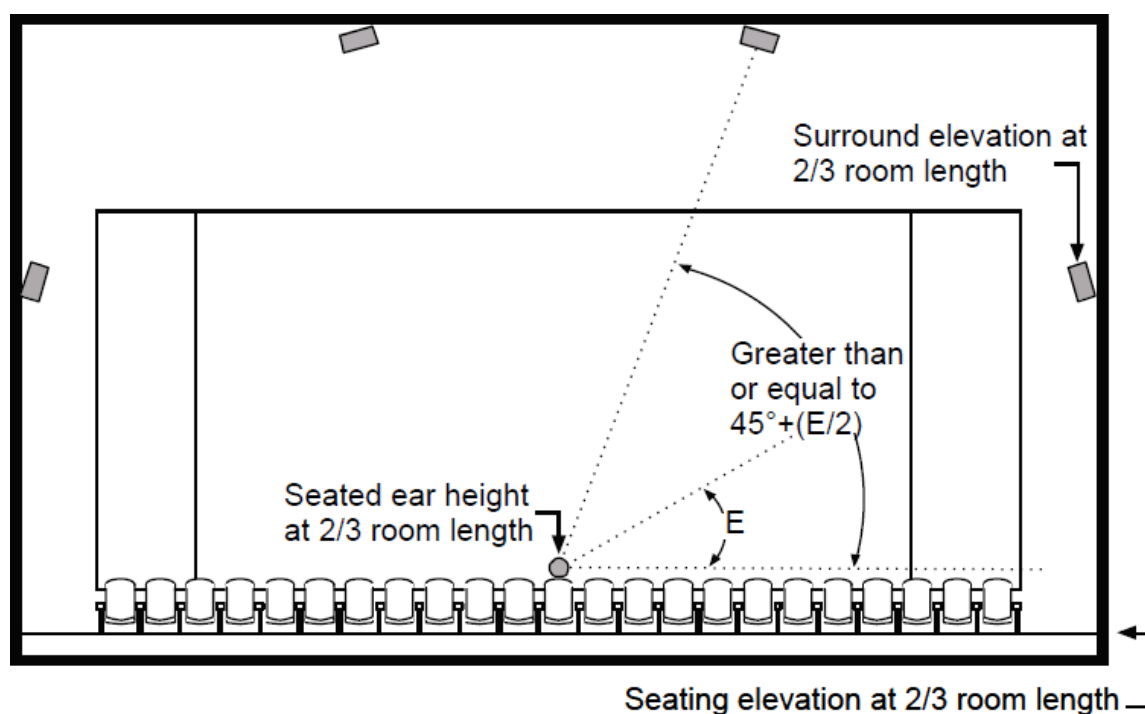

2.6 Selecting brackets and yokes

Mounting brackets and yokes for Dolby DSR1260/DSR1280 are not provided by Dolby. Choose a mounting bracket or yoke that meets the mounting requirements of the auditorium, allowing for needed vertical and horizontal angle adjustment. The bracket or yoke must support the weight of the Dolby DSR1260/DSR1280 (55 lb or 25 kg) with at least a 5:1 safety factor. See section [Dolby DSR1260/DSR1280 dimensions](#) on page 31 for rear mounting pattern dimensions.

2.7 Dolby DSR1260/DSR1280 wire selection

This section can assist you in selecting the correct wire gauge.

Typically, no more than 0.5 dB (or 11%) of power should be lost in the cabling. The Dolby DSR1260/DSR1280 input plates accept an American wire gauge (AWG) of 18 AWG to 6 AWG (1 mm²-16 mm²).



Note: The input terminals are marked with indicators to show the polarity. Per International Electrotechnical Commission (IEC) standards, a positive voltage on the positive marked input results in the transducers moving outward. You must verify the positive and negative markings for each respective product. Always tie the cable down to the available hardware to minimize any buzzing or pullouts. If possible, after wiring is completed, play sound through the speaker to identify any connection issues, buzzing, or rattling.

2.8 Contacting Dolby

You can contact Dolby Cinema Solutions and Support using email or regional telephone numbers. You can also access documentation by visiting the Dolby customer portal.

Contact Dolby Cinema Solutions and Support

- Send an email to cinemasupport@dolby.com.
- Call:
 - Americas: +1-415-645-4900
 - Europe/Middle East/Africa (EMEA): +44-33-0808-7700
 - Asia-Pacific (APAC): +86-400-810-5850
 - Japan: +81-3-4520-9798

Access documentation

Visit customer.dolby.com.

Submit feedback about this documentation

Send an email to documentation@dolby.com

3

Assembling, installing, and aiming the Dolby DSR1260/DSR1280

The following sections provide instructions on how to assemble, install, and aim the DSR1260/DSR1280. In the sections below, tools are required to complete the tasks. Please refer to each section for more details on required tools.



Note: Dolby does not provide mounting brackets or a yoke for the Dolby DSR1260/DSR1280.

The list below is an outline of this chapter:

- [Horn rotation on the Dolby DSR1260/DSR1280](#)
- [Installing brackets](#)
- [Installing a yoke](#)
- [Aiming the Dolby DSR1260/DSR1280 using a laser](#)
- [Installing the safety cable](#)
- [Connecting the Dolby DSR1260/DSR1280](#)

3.1 Horn rotation on the Dolby DSR1260/DSR1280

The Dolby DSR1260/DSR1280 uses a standard four-hole mount bracket, which attaches to the back of the speaker for wall or ceiling installation, or a yoke, which is commonly used for sidewall installations. Please select mounting brackets and yokes that are compliant with section 2.6.

If you are mounting the speaker vertically, as shown below, the horn is oriented correctly from the factory to cover the maximum seating area possible.

Figure 9: Dolby DSR1260 horn dispersion



For vertical installation, you do not need to rotate the horn; proceed to [Installing brackets](#) on page 20.

The speaker can be installed on its side if you need to minimize obstruction to the projector image path. If you are installing the speaker on its side, be sure to rotate the horn so that the arrows are pointing up to ensure optimal audience coverage.

Figure 10: Dolby DSR1260/DSR1280 - Ready for mounting on its side with horn correctly rotated

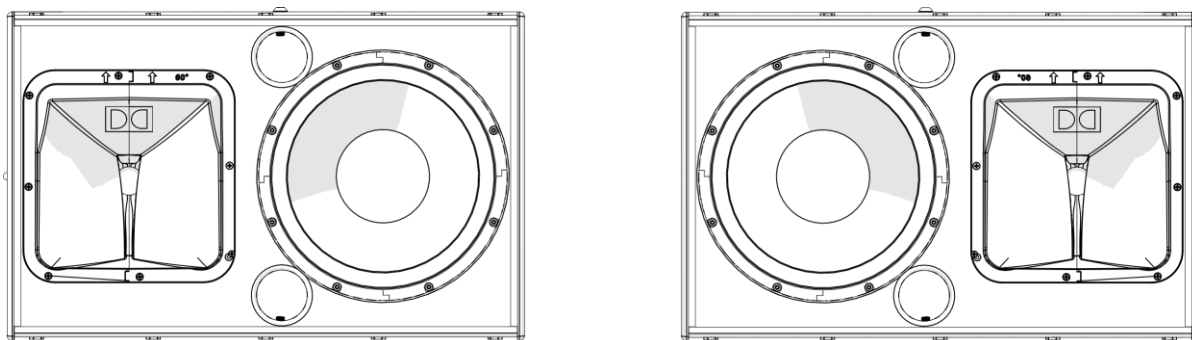

The high-frequency horn needs to be rotated 90 degrees in the cabinet to provide the best coverage for the seating area as shown below.

Figure 11: Rotated horn sound dispersion

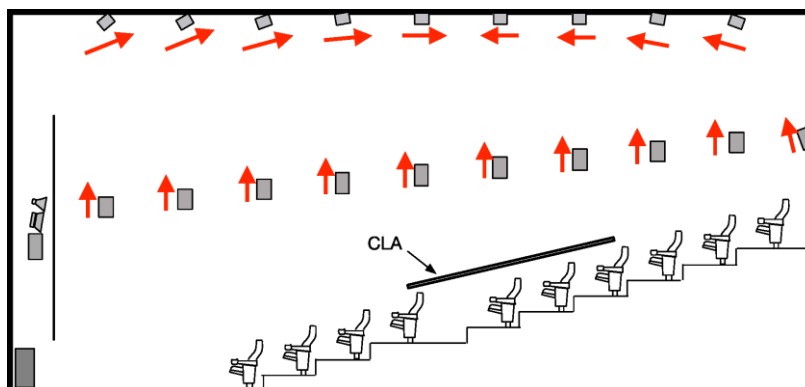

Dolby provides arrows at the top of the horn to indicate the correct orientation for installation of the of the speaker. The arrows should always be pointing toward the ceiling.

Figure 12: Dolby DSR1260/DSR1280 directional arrows on horn

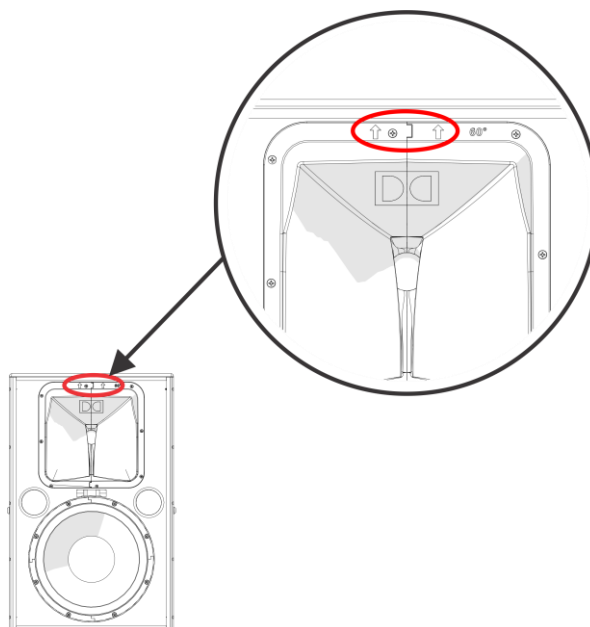

3.1.1 Rotating the horn on the Dolby DSR1260/DSR1280

About this task

The following tools are needed to rotate the horn:

- #2 Phillips screwdriver
- Plastic prying tool

Procedure

1. Remove the 10 Phillips-head screws from the sides of the grille. Keep the screws, as they will be used to reinstall the grille at the end of the procedure.
2. Use the plastic prying tool to pry the grille from one side of cabinet, and then the other side.
Place the grille on a clean surface, so it does not get damaged.
3. Remove the eight Phillips-head screws from high-frequency horn.
4. Use the plastic prying tool to pry the horn away from the cabinet.

Figure 13: Dolby DSR1260/DSR1280 diagram

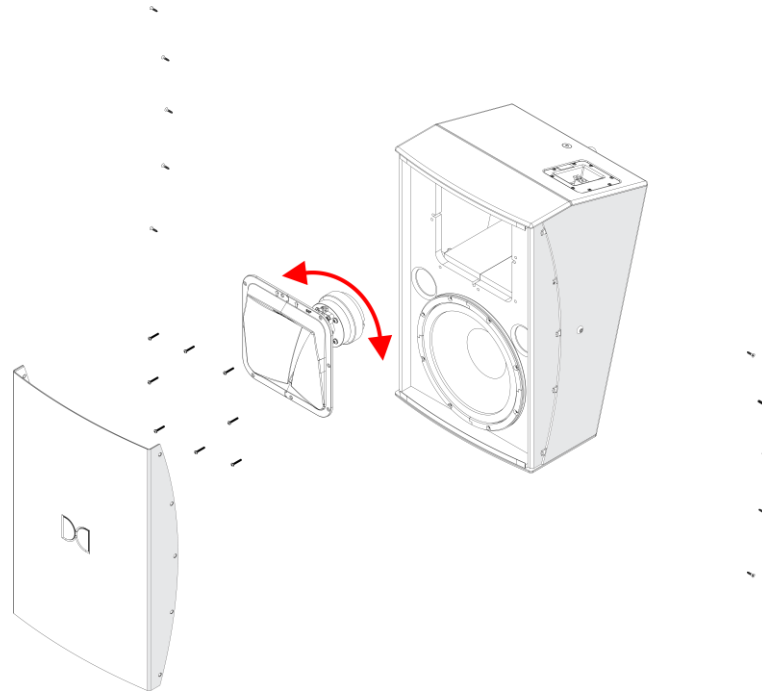

Attention: Do not damage the sealing gasket, and do not pull the horn more than a few inches away from the cabinet due to wire length restriction.



Note: In cases where the speaker is not directly over the RLP, the arrows on the horn (Figure 12) must always point up. In speaker locations where the speaker is not facing directly down, the arrows on the horn should be pointing toward the ceiling (Figure 11).

5. Rotate the horn 90 degrees clockwise or counterclockwise. Ensure that the arrows molded on the horn are pointed up toward the ceiling when the speaker is mounted, as this is essential for accurate coverage.

Figure 14: Horn rotated 90 degrees with arrows facing up (Dolby DSR1260 shown for reference)

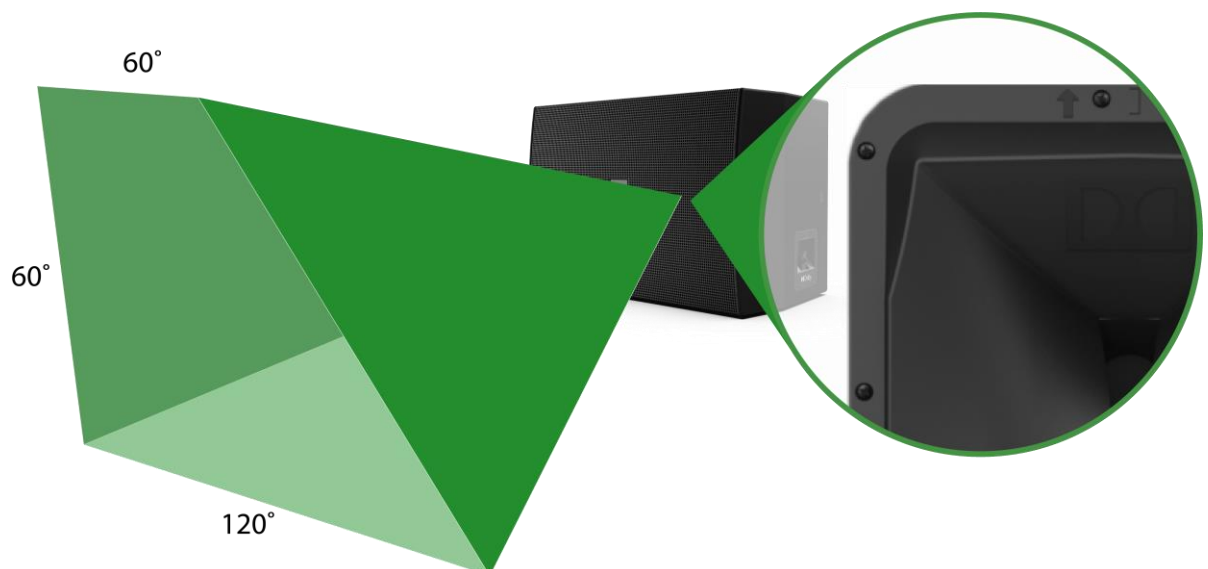

6. Place the horn back on the cabinet face, and then insert the eight Phillips-head screws.



Note: Dolby recommends marking the cabinet with tape to indicate the direction of the arrows of the horn. This will help in identifying the correct orientation while mounting it in the venue.

7. Tighten the eight screws (recommended 1.4 Nm) in a star pattern until the gasket is compressed.
8. Place the grille back on the cabinet (the grill will fit both ways) and lightly press the grille toward the back of the cabinet to seat it while inserting the top-right screw. Tighten the screw to 2.5 Nm.
9. Press the opposite corner of the grille toward the back of the cabinet while inserting a screw in the opposite corner from the first screw. Tighten the screw to 2.5 Nm.
10. Insert the remaining eight screws while pushing lightly on the grille, and then tighten to 2.5 Nm.

3.2 Installing brackets

You must select a bracket that can support the weight of the Dolby DSR1260/DSR1280. The rear panel has an industry-standard hole pattern and will accept a variety of brackets for mounting and aiming.

About this task

The following tool is needed to attach the brackets:

- 4 mm hex driver

Procedure

1. Select four holes from the six that are provided.
The lower bolt-hole configuration provides increased downward tilt, if needed.
2. Loosen the M6 fasteners using the 4 mm hex driver, and then remove them.
3. Place the bracket on the rear panel of the speaker.



Note: Select whether to use the top or bottom holes to secure the bracket. It is important to note that using the bottom bracket holes allows the speaker more ability to tilt down.

Figure 15: Dolby DSR1260/DSR1280 rear panel

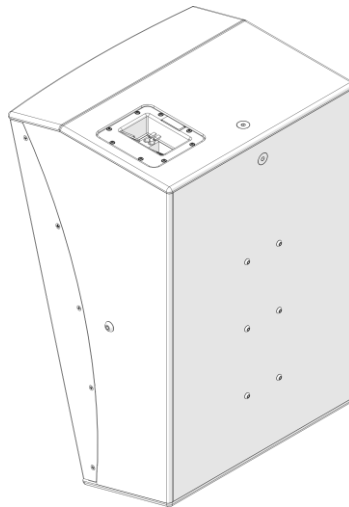
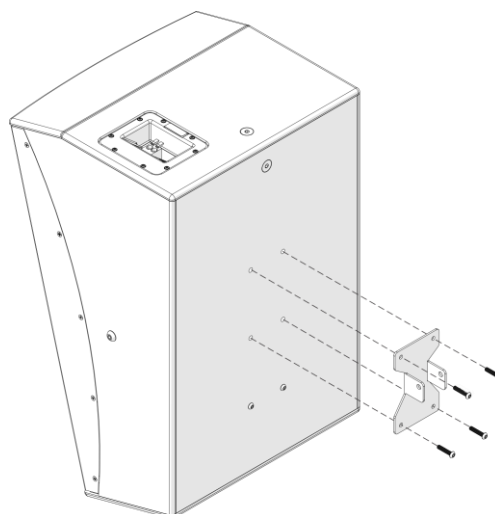

Figure 16: Top bracket holes used to install the bracket



4. Add washers to the M6 bolts (included in the Dolby DSR1260/DSR1280 packaging), and then attach the bracket with the M6-washer combination.
5. Tighten the M6 bolts to the brackets to 2.5 Nm.
Removable thread locking is recommended.

3.3 Installing a yoke

You can install the Dolby DSR1260/DSR1280 using any yoke that is compliant with section 2.6.

About this task

The following tool is needed to attach the yoke:

- 6 mm hex driver

Procedure

1. Remove the M10 bolts from the side of the cabinet, and then adjust and place the yoke according to manufacturer instructions.

 **Important:** If washers are required for proper bolt fit, the installer must provide them.

2. Insert the M10 bolts through the yoke, and then into the cabinet.
3. Angle the cabinet if needed. See [Aiming the Dolby DSR1260/DSR1280](#) for more information.
4. Tighten the bolts to 10 Nm.

Figure 17: Dolby DSR1260/DSR1280 with yoke installed

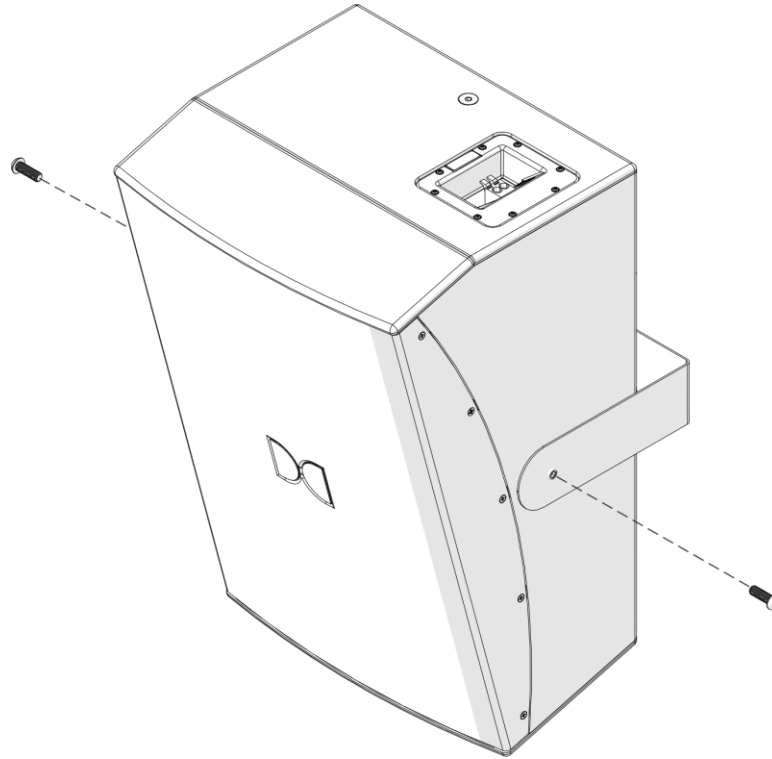

3.4 Aiming the Dolby DSR1260/DSR1280 using a laser

A laser can be used for accuracy when aiming the Dolby DSR1260/DSR1280. Instructions to aim vertically and horizontally are provided in this section.

3.4.1 Using a laser for horizontal aiming

Place a laser pointer as described here to determine the correct horizontal position of the speaker.

About this task

The installer must provide a laser pointer for aiming.

Procedure

1. Place the laser pointer on the outside left or right side of the Dolby DSR1260/DSR1280 enclosure.
2. Keep the laser parallel to the side of the speaker. You may find that there is some vertical (up/down) drift, but this will not affect determining the horizontal angle.
3. Angle the Dolby DSR1260/DSR1280 horizontally until the laser is directed at the specified aiming point.

Figure 18: Placement of laser for horizontal aiming

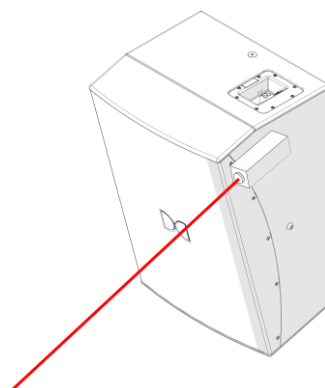

3.4.2 Using a laser for vertical aiming

Place a laser pointer as described here to determine the correct vertical position of the speaker.

Procedure

1. Place the laser pointer on the top of the Dolby DSR1260/DSR1280 enclosure.
2. Keep the laser level with the top of the speaker. You may find that there is some side-to-side drift, but this will not affect determining the vertical angle.
3. Angle the Dolby DSR1260/DSR1280 vertically until the laser is directed at the specified aiming point.

Figure 19: Placement of laser for vertical aiming

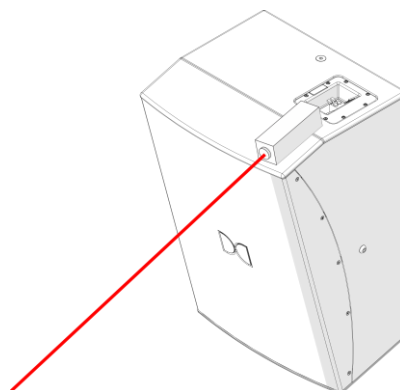

3.5 Installing the safety cable

After mounting the Dolby DSR1260/DSR1280 to the building structure with a bracket or yoke, you must connect a safety cable to an independent point on the building structure. An installer-supplied M10 shoulder-style eyebolt is required to attach a safety cable. Dolby offers an appropriate M10 eyebolt, which can be purchased separately as an accessory item (DPN: 6009242).

About this task

The following tool is needed to remove the M10 bolt on the Dolby DSR1260/DSR1280:

- 6 mm hex driver



Attention: The eyebolt must have a threaded shaft at least 27 mm long to properly engage with the DSR1260/DSR1280 threaded inserts. Based on the weight of the Dolby DSR1260/DSR1280 (55 lb. [25kg]), all installer-supplied safety rigging hardware must have a minimum 5:1 safety factor, or greater if a higher requirement is mandated per local laws. Remove all slack to avoid any shock loading of the cable in the event of a primary rigging failure.

Procedure

1. Choose whether to mount the eyebolt to the top or the rear M10 at the top rear of unit. Dolby recommends using the top safety eyebolt mounting location for wall installations, and the back location for ceiling installations. Additionally, consider which location offers better clearance to the building structure.



Attention: Choose the position that will best avoid side-load to the eyebolt, if the safety eyebolt were to incur loading. Additionally, consider which location offers better clearance to the building structure.

2. Remove the corresponding M10 bolt from the cabinet using the 6 mm hex driver.
3. Take the M10 eyebolt from the packaging, and then place it in the selected M10 threaded hole.
4. Secure the eyebolt firmly, and then attach the installer-supplied cable to the eyebolt building structure.

Figure 20: Eyebolt installed in the rear position

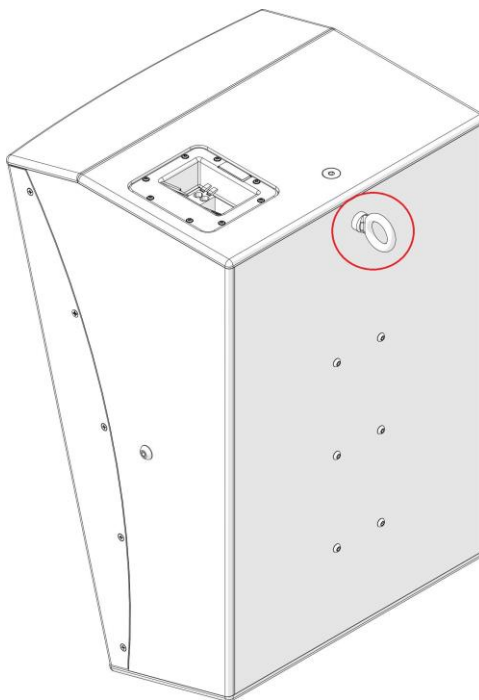
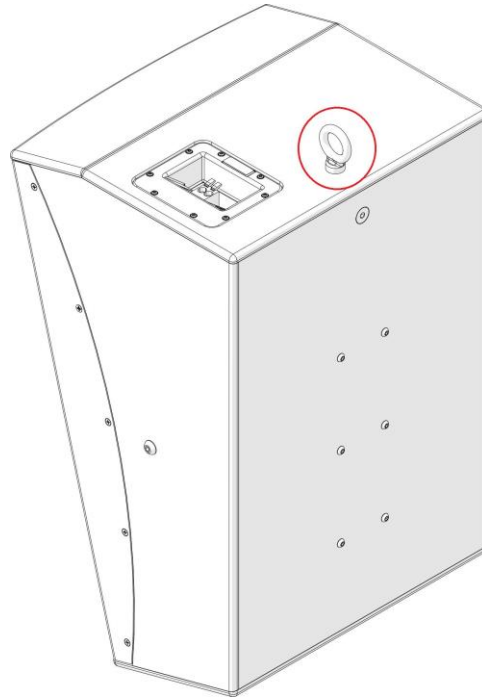

Figure 21: Eyebolt installed in the top position



! **Important:** Size all hardware to allow at least a 5:1 safety factor. Remove slack from safety cable. Consult building plans and a licensed professional engineer, and follow all local laws for overhead mounting.

3.6 Connecting the Dolby DSR1260/DSR1280

This section provides information on how to connect the Dolby DSR1260/DSR1280 to your amplification system using installer-provided speaker cabling.

About this task

To be sure speakers work correctly, you must connect all electrical components properly. You will need a wire stripper to complete tasks in this section.



Caution: Turn off all amplifiers when connecting loudspeaker wiring.



Note: The input terminals are marked with indicators to show their polarity. Per IEC standards, a positive voltage on the positive marked input results in the transducers moving outward.

Procedure

1. Locate the input plate on the top of the Dolby DSR1260/DSR1280.

Figure 22: Input location

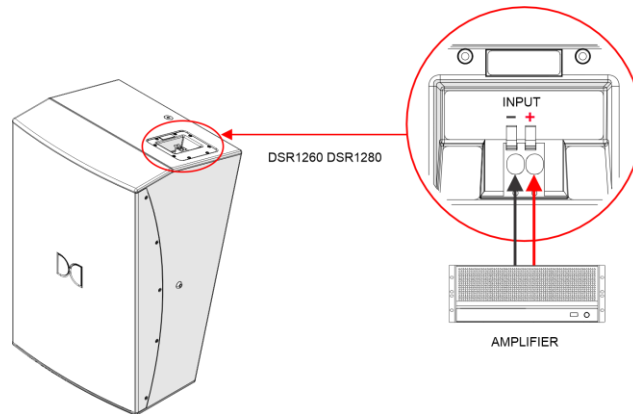

2. Strip back the wire insulation/sheath to 18 mm (0.7").
3. Locate the orange terminal tab, and then push it inward.

Figure 23: Input tabs

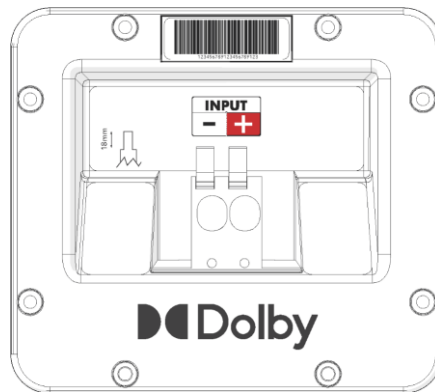

- This terminal tab is spring loaded, and pushing it inward opens the gap in the hole directly below the tab.
4. Insert the wire fully into the terminal tab hole (observing proper polarity), and then release the terminal tab.

The spring-mounted clamp will secure the wire.

 **Note:** In 5.1 and Dolby Surround 7.1 installations, it may be preferable to daisy-chain (series/parallel) several DSR1260 or DSR1280 loudspeakers. This can be achieved by twisting wire pairs and inserting into the input connector per steps 3 and 4. When daisy-chaining loudspeakers, verify that the driving amplifier is rated to handle the resulting load impedance of the combined daisy-chained loudspeakers.

5. Remove any stray wire strands that may be present in and around the terminal tab.

 **Note:** Always tie the cable down to the available hardware to minimize any buzzing or pullouts. If possible, after wiring is completed, play sound through the speaker to identify any connection issues, buzzing, or rattling.

4

Dolby DSR1260/DSR1280 specifications

The Dolby DSR1260/DSR1280 specifications are listed in this chapter.

The list below is an outline of this chapter:

- [Dolby DSR1260 specifications](#)
- [Dolby DSR1280 specifications](#)
- [Dolby DSR1260/DSR1280 dimensions](#)

4.1 Dolby DSR1260 specifications

The Dolby DSR1260 specifications are listed here:

Table 1: Dolby DSR1260 specifications

Specification	Technical data	Notes
Frequency range	55 Hz - 20 kHz	+3dB/-6dB in half space conditions using required DSP
Usable LF response	47 Hz	-10dB in half-space conditions
Coverage window	60 degrees top horizontal, 120 degrees bottom horizontal, 60 degrees vertical	Horizontal top and vertical -6dB averaged to HF horn on-axis response. Horizontal bottom -9dB averaged to on-axis response for near-field proximity compensation
Rated impedance	8 ohms	
Whole Space Sensitivity @ 1 watt	98 dB	Measured with 12dB crest pink noise @ 2.83Vrms in whole space conditions with an 80Hz high pass filter (HPF) and 48dB low pass filter (LPF) @ the rated system high frequency (80Hz is a typical crossover point into Atmos surround bass management)
Half Space Sensitivity @ 1 watt	100 dB	Measured with 12dB crest pink noise @ 2.83Vrms in half space conditions with required high pass filter (HPF) and 48dB low pass filter (LPF) @ the rated system frequency range
Power handling	525W @ 64.8Vrms	12dB crest pink noise for two hours with required HPF and 48dB low pass filter (LPF) @ the rated system frequency range, calculated power based on rated impedance
Power draw	420 W	Measured average power over 5 seconds at the rated Vrms using 12dB crest pink noise with required HPF and 48dB low pass filter (LPF) @ the rated system frequency range. This measured power draw from the amplifier is useful for estimating amplifier sizing in overall system design
Maximum voltage peak	160 Vpk	Vpk over 100 hours using stepped Hann shaped sine wave bursts at 1/3rd oct spacing within the rated passband of the system. This data is useful for setting peak stop limiters and amplifier selection.
Whole Space Maximum continuous SPL @ 1 meter	125 dB	Calculated from rated sensitivity and power
Half Space Maximum Continuous SPL @ 1 meter	127 dB	Calculated from rated sensitivity and power

Table 1: Dolby DSR1260 specifications (continued)

Specification	Technical data	Notes
Whole Space Measured acoustic peak SPL @ 1 meter	136 dB	Measured peak SPL over 5 seconds at rated Vrms using 12dB crest pink noise with required HPF
Half Space Measured acoustic peak SPL @ 1 meter	138 dB	Measured peak SPL over 5 seconds at rated Vrms using 12dB crest pink noise with required HPF
Weight	55 lb. (25 kg)	



Note: These specifications provide typical values and do not represent absolute limits.

4.2 Dolby DSR1280 specifications

The Dolby DSR1280 specifications are listed here:

Table 2: Dolby DSR1280 specifications

Specification	Technical data	Notes
Frequency range	55 Hz - 20 kHz	+3dB/-6dB in half space conditions using required DSP
Usable LF response	47 Hz	-10dB in half-space conditions
Coverage window	80 degrees top horizontal, 130 degrees bottom horizontal, 80 degrees vertical	Horizontal top and vertical -6dB averaged to HF horn on-axis response. Horizontal bottom -9dB averaged to on-axis response for near-field proximity compensation
Rated impedance	8 ohms	
Whole Space Sensitivity @ 1 watt	98 dB	Measured with 12dB crest pink noise @ 2.83Vrms in whole space conditions with an 80Hz high pass filter (HPF) and 48dB low pass filter (LPF) @ the rated system high frequency (80Hz is a typical crossover point into Atmos surround bass management)
Half space sensitivity @ 1 watt	100 dB	Measured with 12dB crest pink noise @ 2.83Vrms in half space conditions with required high pass filter (HPF) and 48dB low pass filter (LPF) @ the rated system frequency range
Power handling	525W @ 64.8Vrms	12dB crest pink noise for two hours with required HPF and 48dB low pass filter (LPF) @ the rated system frequency range, calculated power based on rated impedance

Table 2: Dolby DSR1280 specifications (continued)

Specification	Technical data	Notes
Power draw	420 W	Measured average power over 5 seconds at the rated Vrms using 12dB crest pink noise with required HPF and 48dB low pass filter (LPF) @ the rated system frequency range. This measured power draw from the amplifier is useful for estimating amplifier sizing in overall system design
Maximum voltage peak	160 Vpk	Vpk over 100 hours using stepped Hann shaped sine wave bursts at 1/3rd oct spacing within the rated passband of the system. This data is useful for setting peak stop limiters and amplifier selection.
Whole Space Maximum continuous SPL @ 1 meter	125 dB	Calculated from rated sensitivity and power
Half Space Maximum Continuous SPL @ 1 meter	127 dB	Calculated from rated sensitivity and power
Whole Space Measured acoustic peak SPL @ 1 meter	136 dB	Measured peak SPL over 5 seconds at rated Vrms using 12dB crest pink noise with required HPF
Half Space Measured acoustic peak SPL @ 1 meter	138 dB	Measured peak SPL over 5 seconds at rated Vrms using 12dB crest pink noise with required HPF
Weight	55 lb. (25 kg)	



Note: These specifications provide typical values and do not represent absolute limits.

4.3 Dolby DSR1260/DSR1280 dimensions

The dimensions of the Dolby DSR1260/DSR1280 and its components are described here.

Figure 24: Dimensions

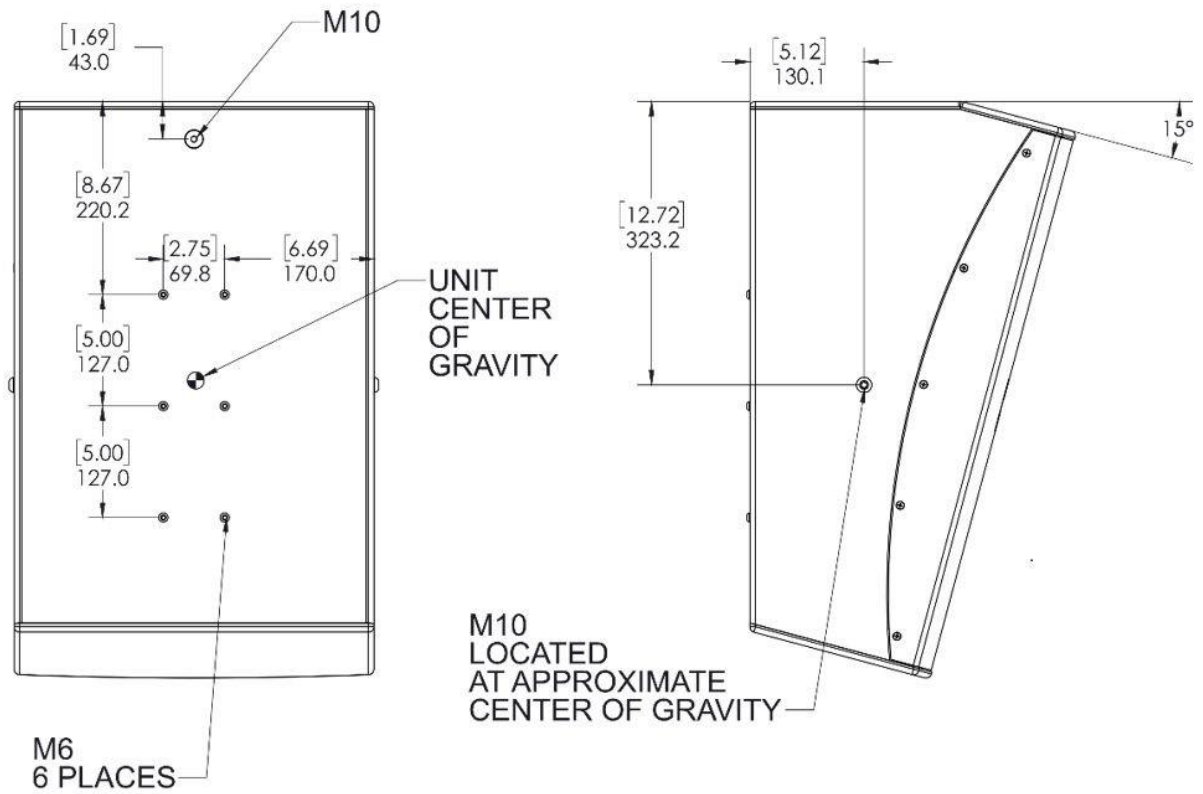
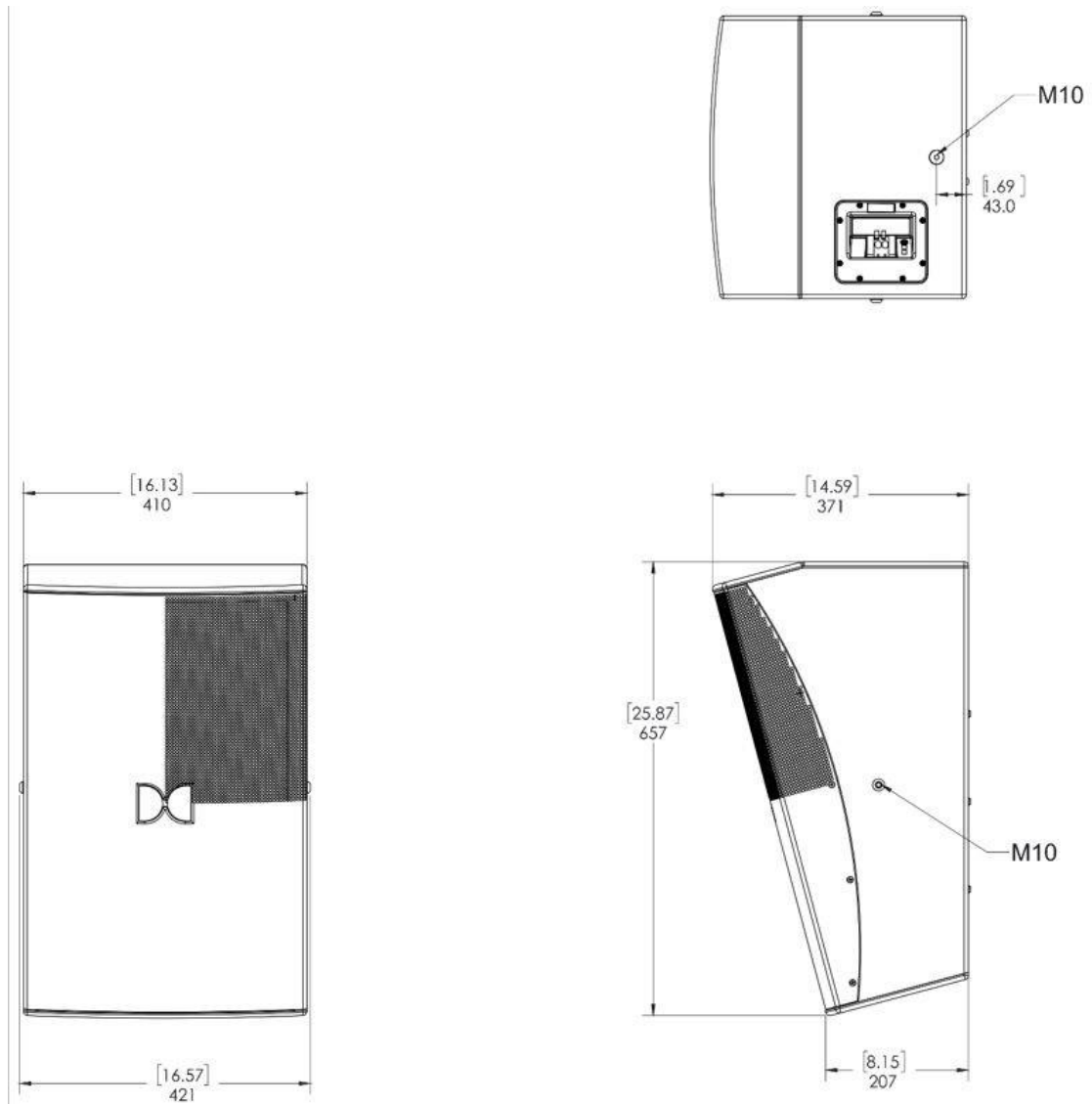

Figure 25: Dimensions



NOTES:
 1. DIMENISONS IN mm [INCHES]

Dolby DSR1260/DSR1280 signal processing

The Dolby DSR1260/DSR1280 digital signal processing is subject to a variety of requirements.

The list below is an outline of this chapter:

- [Dolby DSR1260 signal processing](#)
- [Dolby DSR1280 signal processing](#)

5.1 Dolby DSR1260 signal processing

The Dolby DSR1260 digital signal processing requirements are listed here:

Table 3: Dolby DSR1260 high-pass & low-pass filtration requirements

High-pass filter	Low-pass filter
50 Hz 24 dB (4th order Butterworth)	None

Table 4: Dolby DSR1260 parametric equalization requirements

EQ frequency	Constant Q*		Constant bandwidth*	EQ gain in dB	Notes
80 Hz	1.41 Q	1 BW	1.44	+4 dB	
210 Hz	8 Q	0.18 BW	0.24	+3 dB	
270 Hz	4 Q	0.36 BW	0.5	-2 dB	
2 kHz	6 Q	0.24 BW	0.33	-3 dB	
7 Hz	4 Q	0.36 BW	0.48	-3 dB	
5.3 kHz*	1.41 Q	1 BW	1.44	-4 dB	*optional for x-curve shaping



Note: *There are two principal implementations for parametric EQ filters in DSP processors. You need to select either the Constant Q or Constant Bandwidth mode in your DSP user interface (UI). The DSP UI may provide both Q or Bandwidth (BW) settings, or it may show only BW with no option to input or show Q. To correctly match the intended performance of this Dolby product, confirm with your DSP manufacturer as to which implementation is used. The Dolby CP850 and CP950 cinema processors use constant-bandwidth parametric EQ filters.

Table 5: Dolby DSR1260 limiter requirements

RMS limiting in Vrms	Attack time in ms	Release time in ms	Peak stop in Vpk
64.8	16	256	160

5.2 Dolby DSR1280 signal processing

The Dolby DSR1280 digital signal processing requirements are listed here:

Table 6: Dolby DSR1280 high-pass & low-pass filtration requirements

High-pass filter	Low-pass filter
50 Hz 24 dB (4th order) Butterworth	None

Table 7: Dolby DSR1280 parametric equalization requirements

EQ frequency	Constant Q*		Constant bandwidth*	EQ gain in dB	Notes
80 Hz	1.41 Q	1 BW	1.44	+4 dB	
210 Hz	8 Q	0.18 BW	0.24	+3 dB	
270 Hz	4 Q	0.36 BW	0.5	-2 dB	
2 kHz	6 Q	0.24 BW	0.33	-3 dB	
5.3 kHz*	1.41 Q	1 BW	1.44	-4 dB	



Note: *There are two principal implementations for parametric EQ filters in DSP processors. You need to select either the Constant Q or Constant Bandwidth mode in your DSP user interface (UI). The DSP UI may provide both Q or Bandwidth (BW) settings, or it may show only BW with no option to input or show Q. To correctly match the intended performance of this Dolby product, confirm with your DSP manufacturer as to which implementation is used. The Dolby CP850 and CP950 cinema processors use constant- bandwidth parametric EQ filters.

Table 8: Dolby DSR1280 limiter requirements

RMS limiting in Vrms	Attack time in ms	Release time in ms	Peak stop in Vpk
64.8	16	256	160



System limiters

You can use the RMS limiter in the DSP to set the system limiters.

The list below is an outline of this chapter:

- [Setting system limiters](#)

6.1 Setting system limiters

Use the information provided in this section to set the system limiters.

About this task

We recommend that you set up the system gain structure with the amplifier channel volumes turned all the way up if the volume setting is easily accessible by any user, such as via a front-panel knob that is not behind a security panel. Disconnecting the loudspeakers from the amplifier during this process will most likely result in conservative settings. You can connect the loudspeakers to the amplifier during this process if caution is observed when increasing the stimulus level and confidence in the measuring setup is secured. In addition, we recommend wearing hearing protection when setting up system limiters via the following procedure.



Caution: Loudspeaker damage as a result of exceeding the power handling specifications defined in Dolby DSR1260/DSR1280 specifications is not covered under the warranty.



Caution: Hearing damage can occur by prolonged exposure to excessive sound pressure level (SPL); the loudspeaker is easily capable of generating SPL sufficient to cause permanent hearing damage to performers, production crew, or audience members. Caution should be taken to avoid prolonged exposure to SPL in excess of 90 dB.

It is recommended to set the system limiter for each amplifier channel individually. However, you may copy the limiter settings to other channels if those channels share identical loudspeaker models, identical amplifier models, and identical gain structure in the signal path (including any amplifier front-panel volume controls).

Procedure

1. Connect a wide-bandwidth multimeter with averaging to the amplifier output.
A wide-bandwidth meter has a rated measuring bandwidth of at least 20 kHz with an averaging function that is more than five seconds (very important for low-frequency outputs).
2. Access the RMS limiter setting in the DSP and set it to the maximum value, such that no limiting should occur.
3. Set the attack and release times based on the high-pass filter (HPF), according to the recommended digital signal processing settings for the respective loudspeaker being measured. If that data is not available, we recommend these settings:
 - HPF <30 Hz: attack 45 ms, release 720 ms
 - HPF 30 Hz to 59 Hz: Attack 16 ms, release 256 ms
 - HPF 60 Hz to 99 Hz: Attack 8 ms, release 128 ms
 - HPF 100 Hz to 224 Hz: Attack 4 ms, release 65 ms
 - HPF 225 Hz to 449 Hz: Attack 2 ms, release 32 ms
 - HPF 450 Hz to 999 Hz: Attack 1 ms, release 16 ms
 - HPF 1 kHz to 1.99 kHz: Attack 0.5 ms, release 8 ms
 - HPF >2 kHz: attack 0.3 ms, release 4.8 ms
4. Mute all outputs into the system, except for the output you are setting.
5. Play low-level pink noise into the amplifier channel, and then confirm that the expected loudspeaker is playing (if the loudspeaker is connected to the amplifier) and the multimeter is reading the voltage.
6. While monitoring the meter, slowly turn up the pink noise until the V_{rms} is at the published rating.
For low-frequency outputs, an average of at least five seconds at the same pink-noise level is required for the reading to stabilize. Typically, some amplifier clipping will occur. However, if the amplifier clipping light is almost solid, stop increasing the pink noise and leave it at a V_{rms} level below the published rating.
7. While pink noise is playing at the rated V_{rms} (or there is heavy amplifier clipping), turn down the threshold on the root mean square (RMS) limiter block until the measured V_{rms} goes down slightly.
8. Turn up the stimulus gain, and then confirm that the V_{rms} does not increase beyond the rated V_{rms} . If it does, turn down the limiter threshold again until the V_{rms} is not above the loudspeaker rating when the stimulus is driven heavily.

7

Documentation revision history

The documentation revision history lists the date, issue number, and description of all publications of the *Dolby DSR1260/DSR1280 Owner's Manual*.

Date	Issue	Description
01 January 2022	Issue 1	Initial release
01 January 2024	Issue 2	Revisions for table 4 and table 7