



# Dolby 218-I

## Owner's Manual

1 January 2023  
Issue 1

---

# Notices

## Copyright

© 2023 Dolby Laboratories. All rights reserved.

### **Dolby Laboratories, Inc.**

1275 Market Street  
San Francisco, CA 94103-1410 USA  
Telephone 415-558-0200  
Fax 415-645-4000  
<http://www.dolby.com>

## Trademarks

Dolby and the double-D symbol are registered trademarks of Dolby Laboratories, Inc.

The following are trademarks of Dolby Laboratories:

Dialogue Intelligence™	Dolby Theatre®
Dolby®	Dolby Vision®
Dolby Advanced Audio™	Dolby Vision IQ™
Dolby Atmos®	Dolby Voice®
Dolby Audio™	Feel Every Dimension™
Dolby Cinema®	Feel Every Dimension in Dolby™
Dolby Digital Plus™	Feel Every Dimension in Dolby
Dolby Digital Plus Advanced	Atmos™ MLP Lossless™
Audio™ Dolby Digital Plus Home	Pro Logic®
Theater™ Dolby Home Theater®	Surround EX™

All other trademarks remain the property of their respective owners.

## Product model

This documentation applies to: Dolby 218-I.

## Limited warranty and warranty exclusions

THE LIMITED WARRANTY AND WARRANTY EXCLUSIONS MAY BE FOUND AT THE FOLLOWING URL: <http://www.dolby.com/us/en/about/warranty-and-maintenance-policies.html>

---

# Table of Contents

<b>Chapter 1 Introduction .....</b>	<b>1</b>
1.1 218-I Overview .....	1
1.2 218-I Specifications .....	1
1.3 218-I Processor Settings .....	2
<b>Chapter 2 Installing the Dolby 218-I .....</b>	<b>3</b>
2.1 Rigging the 218-I for Overhead Installations .....	3
2.1.1 Tools Required.....	3
2.1.2 Installing the 218-I.....	3
2.1.3 Connecting the Safety Cable .....	4
2.2 Connecting Audio .....	5
2.3 Finalizing the Installation .....	6
2.4 Dimensions .....	6
<b>Appendix A Environmental Compliance and Regulations.....</b>	<b>7</b>
A. 1 EU Environmental Regulations and Compliance.....	7
A. 2 Russian Environmental Regulations and Compliance.....	7
<b>Appendix B Setting System Limiters .....</b>	<b>8</b>
B. 1 Setting up System Limiters .....	8

# Important safety and regulatory information



## Safety

INSTALLER ASSUMES ALL RESPONSIBILITY AND LIABILITY FOR THE INSTALLATION OF THIS PRODUCT.

No information contained in this guide is intended as a warranty on the part of Dolby. Anyone using this information assumes all liability arising from its use. Product abuse, use of the product not in accordance with Dolby instructions, or use in an application for which the product has not been designed is not covered under any Dolby warranty, nor is Dolby liable for any loss or damage.

Installation must be performed by qualified, licensed, and insured installers, and installed in accordance with all laws, rules, and regulations applicable to the installation site. Failure to do so could result in serious personal injury or even death. Prior to installing this product, read and completely understand the installation instructions. You must read these instructions to prevent personal injury and property damage. Keep the installation instructions in an easily accessible location for future reference.

A licensed professional engineer must approve the placement and method of attachment to the building structure prior to the installation of the system.

All information presented herein is based upon materials and practices common to North America and may not directly apply to other countries because of differing material dimensions, specifications, and/or local regulations. Installers in other countries should consult with appropriate engineering and regulatory authorities for specific guidelines.

Any supplied rigging hardware is intended only for use with the specified loudspeaker(s). The installer assumes all risk of loss and/or injury arising out of the use of the supplied rigging hardware with any other loudspeaker. All other rigging is considered part of the venue and/or installer-supplied equipment and is not addressed in this guide. This guide is not a comprehensive source for rigging in general. Installer assumes all responsibility for ensuring that accepted rigging and safety practices are employed. Installer assumes all responsibility for the appropriate use of Dolby supplied rigging hardware and follows at a minimum all applicable laws, rules, and regulations in force for each venue.

Make sure that no water pipes, natural gas lines, electrical wire, or conduit are present where the speaker is to be installed. Cutting or drilling into water pipes, natural gas lines, electrical wire, or conduit could cause serious personal injury or property damage.

Dolby is not responsible for the application of its products for any purpose or the misuse of this information for any purpose. Furthermore, Dolby is not responsible for the abuse of its products caused by avoiding compliance with inspection and maintenance procedures or any other abuse.

Proper selection of mounting hardware is not included; proper assembly and installation of mounting hardware, including, but not limited to, selection of appropriate weight-bearing support and bracket use, are the exclusive responsibility of the installer. Dolby disclaims any liability, including damage or injury, for the use of mounting hardware supplied by any party other than Dolby. Any modification to

the speaker system hardware provided by Dolby (for example, mounting by drilling holes into the speaker system) will render the product warranty null and void.



**Caution:** Use proper lifting techniques when working with heavy objects to avoid personal injury.

No open flame sources should be placed on or near the apparatus. Do not install near any heat sources such as radiators, heat registers, stoves, or other equipment that produces heat.

Storage temperature: -4 to +140°F (-20 to +60°C). The products covered by this manual are not intended for use in high-moisture environments. Moisture can damage the product and cause corrosion of electrical contacts and metal parts. Avoid exposing the speakers to direct moisture. Keep speakers out of extended or intense direct sunlight. Premature product failure or serious personal injury could occur if this product is used outdoors or in wet indoor environments.



**High temperature warning:** Loudspeaker system may reach elevated temperatures during operation. Always remove all drive signals and allow ample time for the system to cool down prior to handling.

Hearing damage can occur by prolonged exposure to excessive sound pressure level (SPL); the loudspeaker is easily capable of generating SPL sufficient to cause permanent hearing damage to performers, production crew, or audience members. Caution should be taken to avoid prolonged exposure to SPL in excess of 90 dB.

This product is intended for indoor use only.

Do not block any ventilation openings. Install in accordance with the instructions as detailed in this manual and the Product Information document.

Do not install near any heat sources, such as radiators, heat registers, stoves, or other apparatus (including amplifiers) that produce heat.

When a rolling cart is used, use caution when moving the cart/apparatus combination to avoid injury.

Refer all servicing to qualified service personnel. Servicing is required when the apparatus has been damaged in any way.

This product may require installation in a restricted access location. Please refer to this manual and to the Product Information document.

**Warning:**



To reduce electric shock, do not expose the apparatus to dripping or splashing; no objects filled with liquids, such as mugs, shall be placed on the apparatus.

**Caution:**



Troubleshooting must be performed by a trained electrician. To reduce the risk of electric shock, do not attempt to service this equipment unless you are qualified to do so.

**Caution:**



This symbol that appears on the unit and/or instruction manual is intended to alert the user to the presence of important safety operating and maintenance instructions.

**Warning:**

This symbol that appears on the unit and/or instruction manual is intended to alert the user to the presence of uninsulated "dangerous" voltage within the product's enclosure that may be of sufficient magnitude to constitute a risk of electric shock to persons.

**High temperature warning:**

This symbol that appears on the unit and/or the instruction manual is intended to alert the user that the item can be hot and that care must be taken accordingly.

**EU Environmental regulations/ compliance and product disposal information**

Restriction of Hazardous Substances Directive (RoHS): All Dolby products comply with the requirements of the EU RoHS Directive. This product is electronic equipment and should be disposed of in accordance with all applicable laws.

Do not dispose as household waste. Do not dispose of the product in a fire. Please dispose of this product by taking it to your local electronic waste collection point or recycling center. For information regarding where to recycle electronic equipment, contact your local dealer. For additional information regarding Waste Electrical and Electronic Equipment (WEEE) and product disposal go to <http://dolby.com/us/en/about/environmental-commitment.html>.

**Russian environmental regulations and compliance**

This product complies with Russia EAC RoHS requirements.



# Introduction



## 1.1 218-I Overview

The Dolby 218-I is a high performance flyable subwoofer for use in cinema auditoriums and professional applications. The unit contains sixteen M10-1.5 rigging points at convenient locations around the loudspeaker. For mounting to the building structure, you can attach rigging hardware, as described in [Section 2.1](#).



Figure 1-1 Dolby 218-I

## 1.2 218-I Specifications

Following are the 218-I general specifications:\*

- Frequency response: 35 Hz to 180 Hz <sup>1</sup>
- Sensitivity 1Watt @ 1 M: 102 dB <sup>2</sup>
- Nominal impedance: 4 ohms
- Continuous power rating: 1,200 watts <sup>3</sup>
- Maximum continuous rated SPL at 1 meter: 133 dB
- Coverage angle: Omnidirectional
- Drivers: Two 18-inch low frequency
- Barrier strip: Accepts 16- to 12-gauge wire
- Size:
  - Width: 35.01 inches (889 millimeters)
  - Height 20.23 inches (513 millimeters)
  - Depth: 34.71 inches (882 millimeters)
- Net weight: 128 pounds (58.1 kilograms)
- Shipping weight: 143 pounds (64.9 kilograms)

1. 6 dB in half-space conditions using required processing

2. Measured with 12 dB crest pink noise @ 2 Vrms in ground plane conditions with required HPF and LPF. Sensitivity interpolated to 1m

3. 6 dB crest pink noise for one hour with required HPF and LPF, calculated power based on minimum impedance

\* Dolby reserves the right to make changes to existing products without notice.

### 1.3 218-I Processor Settings

Following are the 218-I processor settings:

Crossover Section	Frequency	Slope
Highpass filter	28 Hz	24 dB octave (fourth order) Butterworth
Lowpass filter	80–160 Hz	24 dB octave (fourth order) Butterworth

Limiting Section	Threshold/RMS Voltage	Attack	Release	Peak Stop Voltage
See <a href="#">Appendix B</a>	64 V	45 ms	720 ms	126 V



# Installing the Dolby 218-I

# 2

## 2.1 Rigging the 218-I for Overhead Installations

The 218-I provides sixteen M10-1.5 rigging points to attach installer-supplied rigging hardware. There are four rigging points on each of the subwoofer long sides. You can purchase eyebolts from Dolby or a 3rd party supplier.



---

**Warning:** CONSULT A PROFESSIONAL MECHANICAL OR STRUCTURAL ENGINEER TO APPROVE ALL ATTACHMENTS TO BUILDING STRUCTURE. THIS APPARATUS MUST BE INSTALLED BY LICENSED PROFESSIONAL INSTALLERS. IF NOT INSTALLED ON THE BUILDING STRUCTURE PROPERLY, THIS APPARATUS COULD FALL, CAUSING PERSONAL INJURY OR DEATH. SUSPENSION OF HARDWARE COMPONENTS MUST BE CALCULATED WITH A GIVEN SAFETY FACTOR TO BE WITHIN THEIR RESPECTIVE WORKING LOAD LIMITS. INSPECT ALL COMPONENTS BEFORE INSTALLATION. ALL LOCAL BUILDING AND SEISMIC CODES MUST BE ADHERED TO.

---

### 2.1.1 Tools Required

- 6mm Allen wrench to remove the existing bolts. After removal, you can attach installer-supplied rigging hardware or the optional eyebolts to the available M10-1.5 installation points.

### 2.1.2 Installing the 218-I

Safe overhead rigging practices require an understanding of the proper methods and are outside the scope of this guide. All installer-supplied rigging hardware must have a minimum 5:1 safety factor based on the weight of the 218-I. You should use only the four attachment points facing the hanging surface.



---

**Warning:** THE THREADS OF M10-1.5 INSTALLER-SUPPLIED RIGGING HARDWARE THAT ATTACH TO THE APPARATUS MUST EXTEND A MINIMUM OF 1.25-INCHES (31.8 mm) INTO THE CABINET BUT NOT EXCEED 2.25-INCHES (57.2 mm). HARDWARE MUST HAVE A 5:1 SAFETY FACTOR, OR GREATER IF A HIGHER REQUIREMENT IS MANDATED PER LOCAL LAWS. THE M10-1.5 INSERTS ON THE CABINET SIDES SHOULD NOT BE USED FOR EYEBOLTS THAT PULL AT AN ANGLE GREATER THAN 45 DEGREES TO THE LOAD. HARDWARE MUST BE SECURELY TIGHTENED AND THE WEIGHT EVENLY DISTRIBUTED THROUGH THE FOUR ATTACHMENT POINTS.

PREVIOUS SLS VERSIONS OF THIS PRODUCT USED IMPERIAL MEASUREMENTS AND 3/8"-16 RIGGING POINTS & EYEBOLTS.

The following figure shows examples of the 218-I rigging points and flying options.

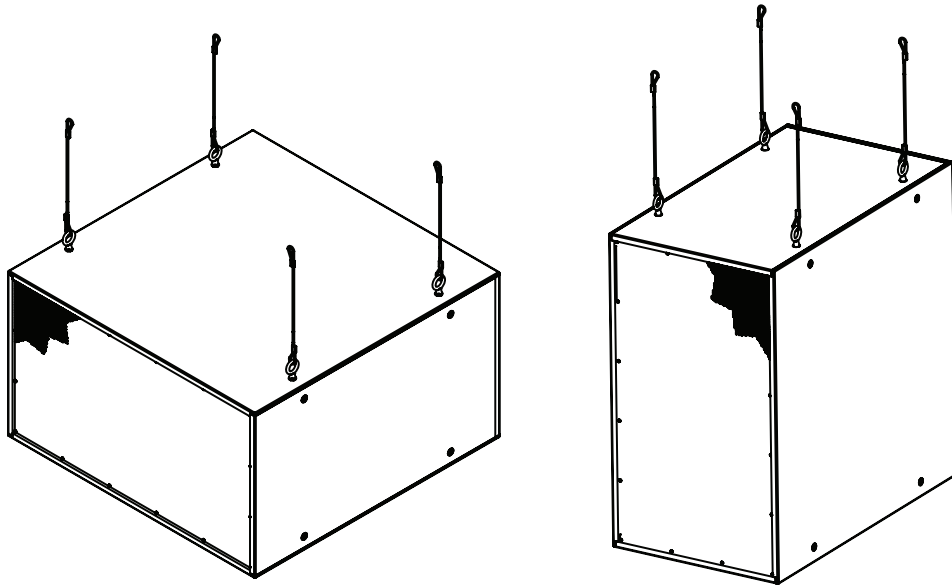

Figure 2-1 Rigging Points and Flying Options

### 2.1.3 Connecting the Safety Cable

After attaching the 218-I to the building structure, you must connect a secondary safety attachment point to an independent point on the building structure. Any of the unused M10-1.5 rigging points are available for attaching an installer-supplied safety cable. Based on the weight of the 218-I, all installer-supplied safety rigging hardware must have a minimum 5:1 safety factor, or greater if a higher requirement is mandated per local laws. Remove all slack to avoid any shock loading of the cable in case of a primary rigging failure.



**Warning:** INSTALLER-SUPPLIED RIGGING HARDWARE MUST HAVE A MINIMUM 5:1 SAFETY FACTOR BASED ON THE WEIGHT OF THE APPARATUS. YOU MUST SECURELY TIGHTEN THE HARDWARE. REMOVE ALL SLACK FROM THE CABLE. REPLACE THE CABLE IF IT HAS BEEN PULLED DUE TO A PRIMARY RIGGING FAILURE.

REMOVABLE THREAD LOCKING IS RECOMMENDED ON ALL FASTENERS.

## 2.2 Connecting Audio

The input PLATE accepts 18 AWG to 6 AWG (1 mm<sup>2</sup> - 16 mm<sup>2</sup>) wire. Always use industry-standard practices for selecting wire gauge, based on the product power rating and cable length. Note that the barrier strip is marked with a plus (+) or red indicator to show the polarity. Per IEC standard, a positive voltage on the positive marked input results in the low-frequency drivers moving outward. Always tie down the cable to available hardware to minimize any buzzing or pullouts.



---

**Warning:** TURN OFF ALL AMPLIFIERS WHEN CONNECTING THE LOUDSPEAKER WIRING

---

## 2.3 Finalizing the Installation

- Make sure that the audio wiring is secure and that vibration from the speaker does not cause any buzzing or rattling.
- Install all fasteners back into their threaded inserts to prevent air leaks.
- Check any hanging rigging for slack.
- Check the safety cable to ensure there is no slack, rubbing, buzzing, or rattling, and that the safety cable cannot short out exposed speaker wiring.
- If possible, play sound through the speaker to identify any connection issues, buzzing, rattling, or vibrations.

## 2.4 Dimensions

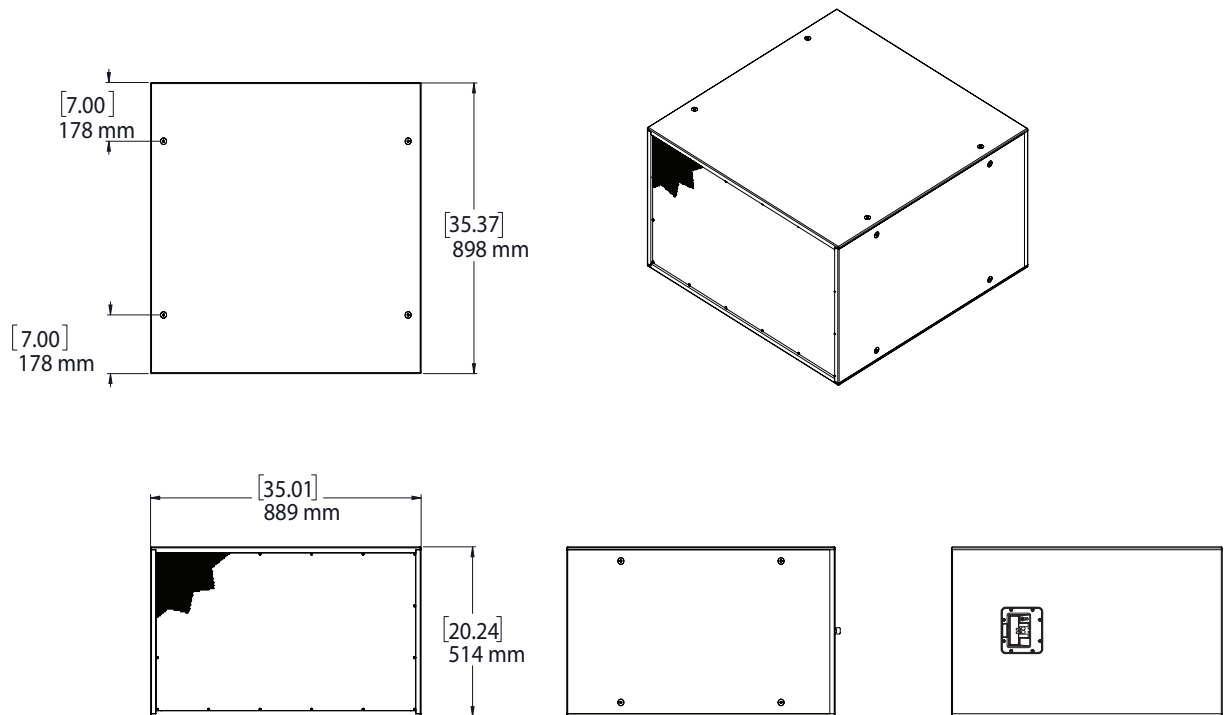

Figure 2-3 Dimensions in [Inches] and Millimeters

# Environmental Compliance and Regulations

## A.1 EU Environmental Regulations and Compliance

Following are the 218-I EU environmental regulations and compliance information.

### Restriction of Hazardous Substances Directive (RoHS)

All Dolby® products comply with the requirements of the EU RoHS Directive. For the Dolby Declarations of Conformity, go to

<http://www.dolby.com/us/en/about/environmental-commitment.html>

### Product End-of-Life Information

This product is electronic equipment and should be disposed of in accordance with all applicable laws. Do not dispose as household waste. Do not dispose of the product in a fire. Please dispose of this product by taking it to your local electronic waste collection point or recycling center. For information regarding where to recycle electronic equipment, contact your local dealer.

For additional information regarding Waste Electrical and Electronic Equipment (WEEE) and product disposal go to

<http://www.dolby.com/us/en/about/environmental-commitment.html>

## A.2 Russian Environmental Regulations and Compliance

Following is the 218-I Russian environmental compliance information.

### Restriction of Hazardous Substances (RoHS)

**Directive** This product complies with Russian EAC RoHS requirements.



# Setting System Limiters

## B.1 Setting up System Limiters

This documentation explains how to set up system limiters to protect your loudspeaker and provide maximum performance when the digital signal processor (DSP), amplifier, and loudspeaker hardware are all variables. The following procedure provides a limiter setting threshold that can protect loudspeakers in a majority of use cases. However, the speaker drivers may still be vulnerable to content issues, such as sustained feedback or large, low-frequency transients below box tuning. Good system design and common sense should be the rule.

1. Obtain an audio source (to generate pink noise) and a true RMS voltage meter with a bandwidth of at least 20 kHz that can average a reading over a period of at least 10 seconds.
2. Complete the room tuning and set the amplifier gain.  
To prevent future user error, consider setting the amplifiers at full gain, unless the amplifier gain setting is hardware or software protected. In such a case, you can optimize the amplifier gain to achieve the best signal-to-noise ratio.
3. After completing the room tuning and setting the amplifier gain, bypass the limiter on the DSP that you are using for protection, and leave all other DSP functions for that output engaged. For example, the highpass filter, crossovers, equalization, and so on.
4. Mute all system outputs except the output that is currently being calibrated.
5. Place the voltage meter across the amplifier +/- output terminals and turn up the pink noise source until the reading on the meter is slightly above the specified Threshold/RMS voltage rating for that speaker driver and its recommended processor settings (see [Section 1.3](#)).
6. Play the pink noise only long enough to obtain a stable RMS average voltage reading. For high-frequency drivers, this is typically five seconds, and for full range loudspeakers or subwoofers, it is typically ten seconds.
7. Set the limiter to a minimum ratio of 100:1, and then input the attack and release times recommended by the speaker manufacturer.
8. Engage the limiter, and decrease the threshold until the voltage is lowered to the specified rating, without changing the pink noise gain.
9. Repeat the above procedure for each driver and/or passive loudspeaker you are using.
10. If a predictive peak stop limiter is available on the DSP, engage it at 6 dB above the RMS setting.
11. Monitor for amplifier clipping. If clipping occurs during system use, lower the peak-stop threshold until the amplifier clips slightly. Alternatively, you can engage the self-contained limiter circuit in the amplifier (if it has such a limiter circuit).  
You need to perform this procedure only once, as long as the combined amplifier-limiter does not change. However, amplifier gain changes modify the limiter action. If the amplifier gain is decreased, protection engages early, which limits driver output. If the amplifier gain is increased, protection engages only after the driver reading is above the safe RMS voltage.